

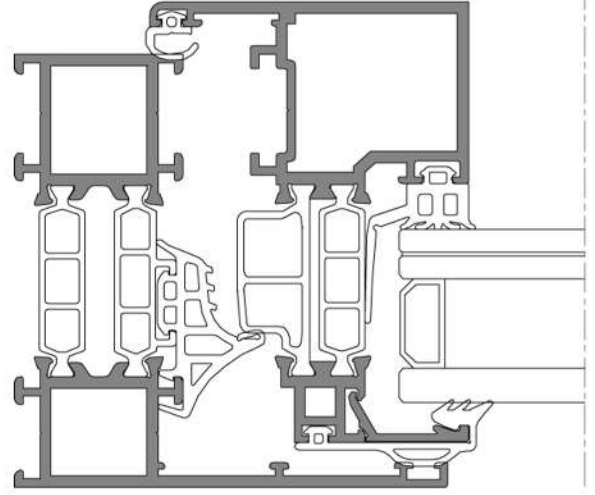

HVT77



TEKNİK ÖZELLİKLER / TECHNICAL PROPORTEIS

KASA DERİNLİĞİ / FRAME DEPTH	77 mm
KANAT DERİNLİĞİ / SASH DEPTH	78,5 mm
ET KALINLIĞI / WALL THICKNESS	2 mm - 3 mm
CAM KALINLIĞI / GLASS THICKNESS	24 - 36 mm
ISI BARIYER / THERMAL BREAK	34 mm
AKS BİNİ / 13 Axis (18)	13 Aks - 18 Bini

PERFORMANS DEĞERİ / PERFORMANCE VALUES

EN 12152 Hava Geçirgenliği / Air Permability	Class 4 - 600 Pa
EN 12154 Su Sızdırmazlığı / Water Tightness	Class 9A - 600 Pa
TS EN 13830 Rüzgar Yüküne Dayanım / Wind Resistance	Class C4 - 1800 Pa
Minimum Termal Isı Yalıtımı / Thermal Insulation Value (UF)	Uf: 1,8 - 2,1 W/(m².K)

UYGULAMA SEÇENEKLERİ / APPLICATION OPTIONS

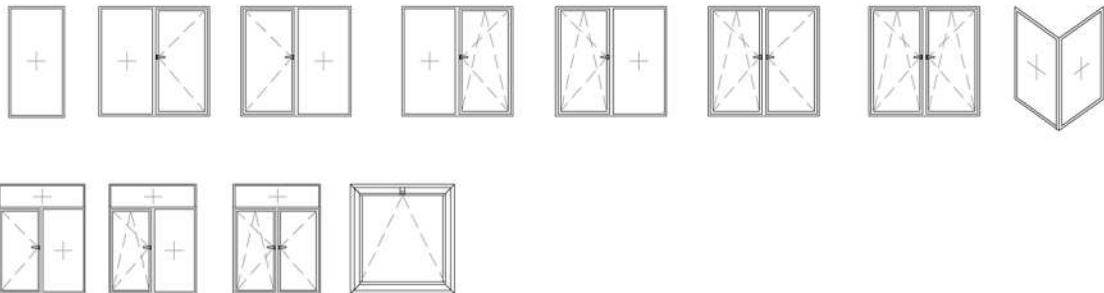

ALÜMİNYUM SANAYİ VE TİC. A.Ş.



AVRASYA CEPHE-DOĞRAMA TEST VE TEKNOLOJİ MERKEZİ A.Ş.

Cumhuriyet Mahallesi 1. Cadde 1. Sokak No:1 81600
II. OSB Beyköy – DÜZCE/TÜRKİYE



Test
TS EN ISO/IEC 17025
AB-0926-T

AB-0926-T

21-004-PR02

05.2021

Deney Raporu Test Report

Sayfa (Page): 1 / 23

Müşterinin adı/adresi

Customer name/address

Akpa Alüminyum San. ve Tic. A.Ş.

Hürriyet Mah. Dr. Cemil Bengü Cad. No:6 Kağıthane / İstanbul

İstek Numarası

Order No.

21-004-PR02

Numunenin adı ve tarifi

Name and identity of test item

AKPA – HVT 77 Sistem / Çift kanat ve 2 sabit ışıklık içeren pencere

AKPA – HVT 77 System / Window including double casements and 2 fixed light

Numunenin kabul tarihi

The date of receipt of test item

13.04.2021

Açıklamalar

Remarks

EN 1026, EN 1027, EN 12211 deney metotları kullanılmıştır.

EN 1026, EN 1027, EN 12211 testing methods were performed.

EN 12207 - Hava Geçirgenliği

Sınıf 4

EN 12207 - Air Permeability

Class 4

EN 12208 - Su Sızdırmazlık

Sınıf 9A

EN 12208 - Watertightness

Class 9A

EN 12210 - Rüzgar Yüklerine Dayanım

Sınıf C4

EN 12210 - Resistance to Wind Load

Class C4

Deneyin yapıldığı tarih

Date of Test

21.04.2021

Deney Raporu Sayfa Sayısı

Number of pages of the test report

23

Avrasya Cephe-Doğrama Test ve Teknoloji Merkezi A.Ş. TÜRKAK'tan AB-0926-T dosya numarası ile TS EN ISO/IEC 17025:2017 standardına göre akredite edilmiştir.

Avrasya Cephe-Doğrama Test ve Teknoloji Merkezi A.Ş. accredited by TÜRKAK under registration number AB-0926-T for TS EN ISO/IEC 17025:2017 as test laboratory"

Türk Akreditasyon Kurumu (TÜRKAK) deney raporlarının tanınırlığı konusunda Avrupa Akreditasyon Birliği (EA) ile Çok Taraflı Anlaşma ve Uluslararası Laboratuvar Akreditasyon Birliği (ILAC) ile karşılıklı tanıma anlaşması imzalamıştır.

Turkish Accreditation Agency (TURKAK) is a signatory to the European co-operation for Accreditation (EA) Multilateral Agreement (MLA) and to the International Laboratory Accreditation Cooperation (ILAC) Mutual Recognition Arrangement (MRA) for the recognition of test reports

Bu deney raporu: Firmamıza ulaşan numunelere deney ve/veya deneyler uygulanarak elde edilmiştir. Müşteriye ait diğer numuneleri kapsamaz.

This test report was prepared after applying test/tests to the samples that are sent to our company. Note that this declaration does not involve other samples of the customer.

Deney ve /veya ölçüm sonuçları, genişletilmiş ölçüm belirsizlikleri (olması halinde) ve deney metotları bu sertifikanın tamamlayıcı kısmı olan takip eden sayfalarda verilmiştir.

The test and/or measurement results, the uncertainties (if applicable) with confidence probability and test methods are given on the following pages which are part of this report.



Kaşe / Seal

28.05.2021

Yayımlandığı Tarih

Date

Deney Sorumlusu

Person in charge of test

Onaylayan

Approval

RPR001/01/09.10.2019

Bu rapor, laboratuvarın yazılı izni olmadan kısmen kopyalanıp çoğaltılamaz.

İmzasız ve mühürsüz raporlar geçersizdir.

This report shall not be reproduced other than in full except with the permission of the laboratory.

Testing reports without signature and seal are not valid

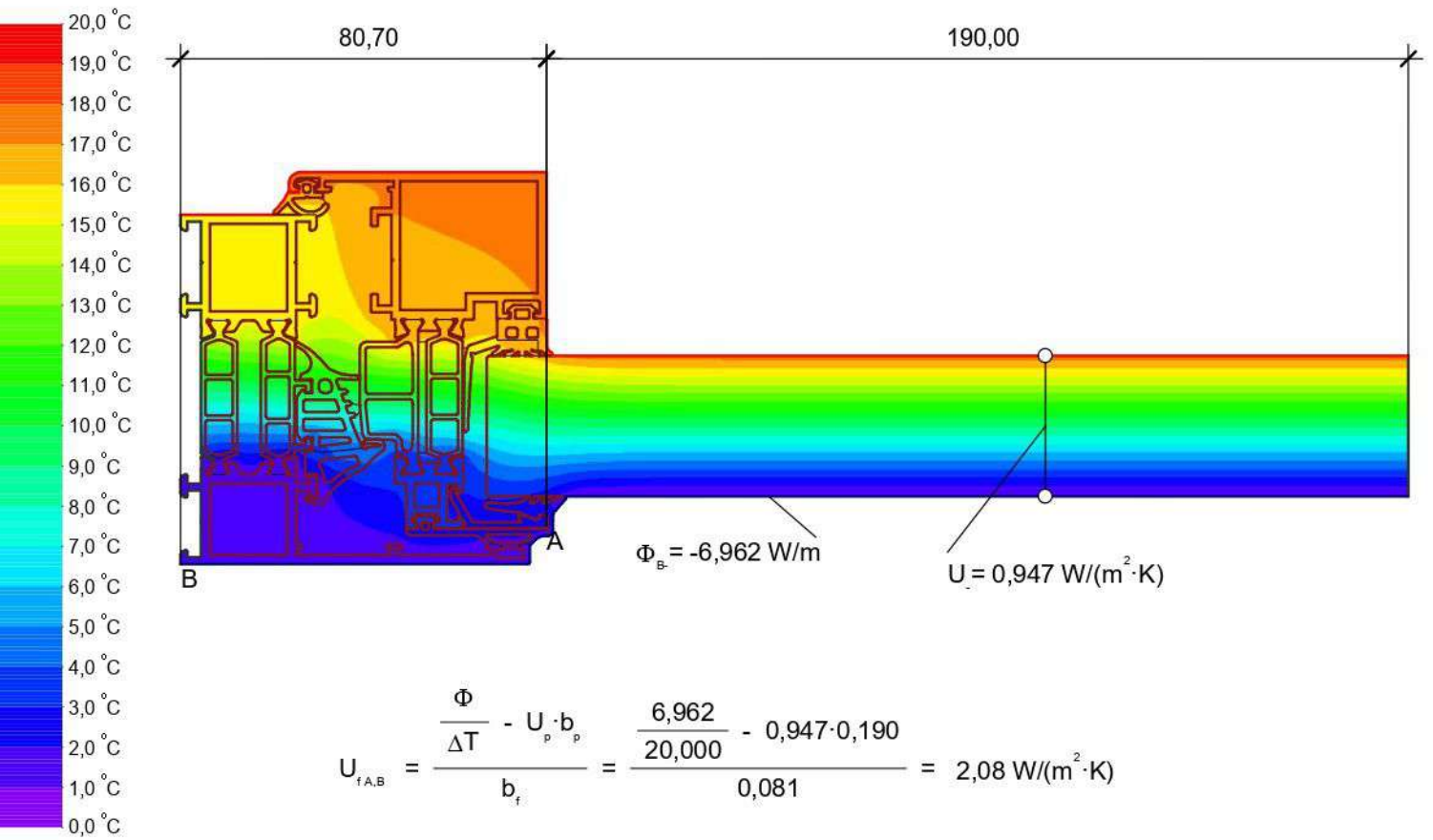

Material	λ [W/(m·K)]	ϵ	Boundary Condition	q [W/m ²]	θ [°C]	R [(m ² ·K)/W]	ϵ
Aluminium (Si Alloys)	160,000	0,900	Epsilon 0.9				0,900
Coex	0,200	0,900	Exterior, frame	0,000	0,040		
EPDM (ethylene propylene diene monomer)	0,250	0,900	Interior, normal, horizontal	20,000	0,130		
Panel	0,035	0,900	Symmetry/Model section	0,000			
Polyamid 6.6 with 25% glass fibre	0,300	0,900					
Unventilated air cavity	anisotropic						



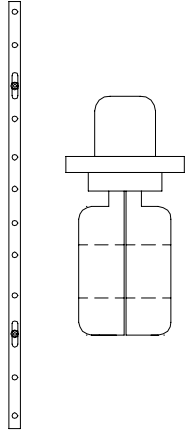
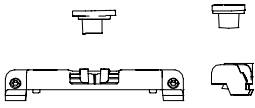
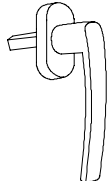
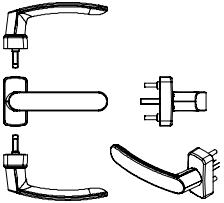
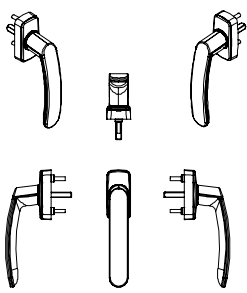
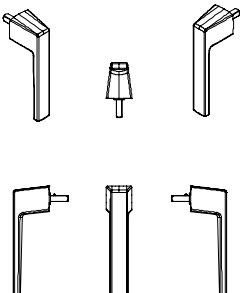

PROF L KES T PROFILE SECTION	PROF L KODU PROFILE CODE	PROF L ADI PROFILE NAME	Jx cm ⁴	Jy cm ⁴	A İRLİK (kg/m) WEIGHT
	77-11619-11628	KASA PROF L FRAME PROFILE	18,58 cm ⁴	45,68 cm ⁴	1,727 kg/m
	77-11629-11620	KASA PROF L FRAME PROFILE	15,18 cm ⁴	41,99 cm ⁴	1,617 kg/m
	77-11618-11619	ORTA KAYIT PROF L MULLION PROFILE	24,10 cm ⁴	49,84 cm ⁴	1,869 kg/m
	77-11621-11620	ORTA KAYIT PROF L MULLION PROFILE	19,95 cm ⁴	45,98 cm ⁴	1,754 kg/m
	77-11632-11619	ORTA KAYIT PROF L MULLION PROFILE	39,67 cm ⁴	53,69 cm ⁴	2,014 kg/m
	77-11619-12262	TAKV YEL ORTA KAYIT PROF L REINFORCED MULLION PROFILE	451,25 cm ⁴	79,11 cm ⁴	4,206 kg/m
	77-11622-11624	KANAT PROF L SASH PROFILE	8,45 cm ⁴	30,77 cm ⁴	1,454 kg/m
	77-11622-11623	KANAT PROF L SASH PROFILE	8,64 cm ⁴	30,83 cm ⁴	1,501 kg/m
	77-11630-11631	ADAPTÖR PROF L ADAPTER PROFILE	-	-	1,868 kg/m
	77-12260-12261	ADAPTÖR PROF L ADAPTER PROFILE	-	-	1,407 kg/m
	77-12350-1953	KÖ E DÖNÜ PROF L CORNER PROFILE	59,38 cm ⁴	59,38 cm ⁴	2,146 kg/m
	11617	CAM YÜKSELTME ÇİTASI GLAZING ELEVATION BEAD	-	-	0,359 kg/m
	11616	CAM ÇİTASI GLAZING BEAD	-	-	0,117 kg/m
	8241	T J PROF L STEM BAR PROFILE	-	-	0,340 kg/m
	1747	CAM ÇİTASI GLAZING BEAD	-	-	0,099 kg/m
	3832	T BA LANTI PROF L CONNECTION PROFILE	-	-	0,175 kg/m
	2045	KÖ E TAKOZ PROF L CORNER WEDGE PROFILE	-	-	1,436 kg/m
	11627	KÖ E TAKOZ PROF L CORNER WEDGE PROFILE	-	-	2,929 kg/m
	1696	KÖ E TAKOZ PROF L CORNER WEDGE PROFILE	-	-	3,340 kg/m
	5022	KÖ E TAKOZ PROF L CORNER WEDGE PROFILE	-	-	2,245 kg/m
	11625	ORTA KAYIT BA LANTI PROF L MULLION CONNECTION PROFILE	-	-	0,990 kg/m
	11626	ORTA KAYIT BA LANTI PROF L MULLION CONNECTION PROFILE	-	-	1,502 kg/m

AKSESUAR ACCESSORY	STOK KODU REFERENCE CODE	AKSESUAR ADI DESCRIPTION	AKSESUAR KODU PRODUCT CODE	PAKET PACK
	03 010103	Ç CAM F T L (KANAT Ç N) INNER GLAZING GASKET (FOR SASH)	HVT77-CF.03	170 mt / paket 10 kg
	03 010105	Ç CAM F T L (KANAT Ç N) INNER GLAZING GASKET (FOR SASH)	HVT77-CF.05	128 mt / paket 10 kg
	03 010107	Ç CAM F T L (KANAT Ç N) INNER GLAZING GASKET (FOR SASH)	HVT77-CF.07	
	03 010111	Ç CAM F T L (KANAT Ç N) INNER GLAZING GASKET (FOR SASH)	HVT77-CF.11	70 mt / paket 10 kg/mt
	03 010113	Ç CAM F T L (KANAT Ç N) INNER GLAZING GASKET (FOR SASH)	HVT77-CF.13	60 mt / paket 10 kg/mt
	03 010115	Ç CAM F T L (KANAT Ç N) INNER GLAZING GASKET (FOR SASH)	HVT77-CF.15	145 mt / paket 10 kg/mt
	03 011240	Ç CAM F T L (KANAT Ç N) INNER GLAZING GASKET (FOR SASH)	HVT77- CF.80	59 mt / paket 10 kg
	03 010500	KANAT FİTİLİ SASH GASKET	HVT77-KBF.15	230 mt / paket 10 kg
	03 010503	DI CAM F T L OUTER GLAZING GASKET	HVT77-DCF.30	210 mt / paket 10 kg/mt
	03 011230	Ç CAM F T L INNER GLAZING GASKET	HVT77-İCF.30	280 mt / paket 10 kg/mt
	03 011231	Ç CAM F T L INNER GLAZING GASKET	HVT77-İCF.40	220 mt / paket 10 kg/mt
	03 010732	Ç CAM F T L INNER GLAZING GASKET	HVT77-İCF.50	185 mt / paket 10 kg/mt
	03 011236	Ç CAM F T L INNER GLAZING GASKET	HVT77- CF.23	255 mt / paket 10 kg
	03 011237	Ç CAM F T L INNER GLAZING GASKET	HVT77- CF.45	66 mt / paket 10 kg
	03 011040	G ZL KANAT F T L HIDDEN VENT GASKET	HVT77-GKF.77	40 mt / paket 10 kg
	03 011037	ORTA B N F T L MIDDLE GASKET	HVT77-OBF.77	1 pk / 20 ad

AKSESUAR ACCESSORY	STOK KODU REFERENCE CODE	AKSESUAR ADI DESCRIPTION	AKSESUAR KODU PRODUCT CODE	PAKET PACK
	03 070305	VULKAN ZE KÖ E BA LANTI (OBF.77 Ç N) VULCANIZED CORNER CONNECTION (FOR OBF.77)	HVT77-KVF.77	1 pk / 20 ad
	03 070301	VULKAN ZE KÖ E BA LANTI (GKF.77 Ç N) VULCANIZED CORNER CONNECTION (FOR GKF.77)	HVT77-KGVF.77	1 pk / 20 ad
	01 120201	AYARLI SPANYOLET KAR ILI I (SETSKURLU) ADJUSTABLE ESPAGNOLETTE STRIKER (BOLTED)	HVT77-TPK.201	1 pk / 100 ad
	01 120217	PVC KANALLI SPANYOLET KAR ILI I PVC GROOVED ESPAGNOLETTE STRIKER	HVT77-PK.217	1 pk / 100 ad
	01 120100	SPANYOLET P M ESPAGNOLETTE PIN	HVT77-TP.100	1 pk / 100 ad
	06 140210	CAM TAKOZU(5X28X80 mm) GLAZING WEDGE 5mm	HVT77-CT.210	1 pk / 1000 ad
	01 010901	S STEM PENCERE MENTE ES (ELOKSALLI) SYSTEM WINDOW HINGE (ANODIZED)	HVT77-PM.901	1 pk / 10 ad
	01 010902	S STEM PENCERE MENTE ES (BEYAZ) SYSTEM WINDOW HINGE (WHITE)	HVT77-PM.902	1 pk / 10 ad
	01 010903	S STEM PENCERE MENTE E (RENKL) SYSTEM WINDOW HINGE (COLORED)	HVT77-PM.903	1 pk / 10 ad
	01 011101	S STEM PENCERE VE KAPI MENTE E (ELOKSALLI) SYSTEM WINDOW HINGE (ANODIZED)	HVT77-PKM.101	1 pk / 10 ad
	01 011102	S STEM PENCERE VE KAPI MENTE E (BEYAZ) SYSTEM WINDOW HINGE (WHITE)	HVT77-PKM.102	1 pk / 10 ad
	01 011103	S STEM PENCERE VE KAPI MENTE E (RENKL) SYSTEM WINDOW HINGE (COLORED)	HVT77-PKM.103	1 pk / 10 ad
	01 011111	S STEM KAPI MENTE E (ELOKSALLI) SYSTEM WINDOW HINGE (ANODIZED)	HVT77-KM.111	1 pk / 10 ad
	01 011112	S STEM KAPI MENTE E (BEYAZ) SYSTEM WINDOW HINGE (WHITE)	HVT77-KM.112	1 pk / 10 ad
	01 011113	S STEM KAPI MENTE E (RENKL) SYSTEM WINDOW HINGE (COLORED)	HVT77-KM.113	1 pk / 10 ad
	01 120230	PVC KANALLI TEK AÇILIM MENTE E (13/18) PVC GROOVED CASEMENT HIGE (13/18)	HVT77-PM.230	1 pk / 100 ad
	01 120250	PVC KANALLI Ç FT AÇILIM MENTE E (13/18) PVC GROOVED CASEMENT HIGE (13/18)	HVT77-PMT.250	1 pk / 100 ad

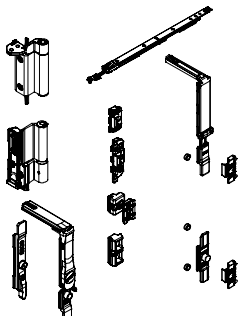
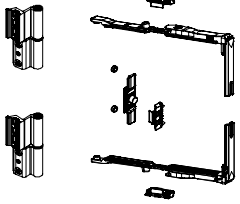
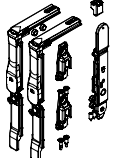
AKSESUAR ACCESSORY	STOK KODU REFERENCE CODE	AKSESUAR ADI DESCRIPTION	AKSESUAR KODU PRODUCT CODE		PAKET PACK
	06 010452	SPANYOLET-80 cm ESPAGNOLETTE-80 cm	HVT77- SP.452		1 pk / 1 ad
	06 010453	SPANYOLET-100 cm ESPAGNOLETTE-100 cm	HVT77- SP.453		1 pk / 1 ad
	06 010454	SPANYOLET-120 cm ESPAGNOLETTE-120 cm	HVT77- SP.454		1 pk / 1 ad
	06 010455	SPANYOLET-140 cm ESPAGNOLETTE-140 cm	HVT77- SP.455		1 pk / 1 ad
	06 010456	SPANYOLET-160 cm ESPAGNOLETTE-160 cm	HVT77- SP.456		1 pk / 1 ad
	06 010457	SPANYOLET-180 cm ESPAGNOLETTE-180 cm	HVT77- SP.457		1 pk / 1 ad
		KANAT SAB TLEME KL PS SASH FIXING CLIP KIT			
	01 200291	SECUST K PENCERE KOLU WINDOW HANDLE	HVT77-RK.291		1 pk / 20 ad
		SIRIUS 7 KARE M L PENCERE KOLU SIRIUS 7x26 WINDOW HANDLE	H77A0771		
		POLAR S 8 KADEMEL PENCERE KOLU POLARIS MV WINDOW HANDLE	H77S5771		
		ALFA M N MAL ST PENCERE KOLU ALFA MINIMAL WINDOW HANDLE	H777701		

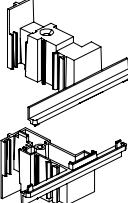
AKSESUAR ACCESSORY	STOK KODU REFERENCE CODE	AKSESUAR ADI SYSTEM TRANSOM CATCH (CLOSED) DESCRIPTION	AKSESUAR KODU PRODUCT CODE	PAKET PACK
	01 020601	EKSENEL KOL (ELOKSALLI) AXIAL HANDLE (ANODIZED)	HVT77-RK.601	1 pk /10 ad
	01 020604	EKSENEL KOL (ELOKSALLI K L TL) AXIAL HANDLE WITH KEYS (ANODIZED)	HVT77-RK604	1 pk /10 ad
	01 020810	FORZA EKSENEL PENCERE KOL YEN (NATUREL) FORZA NEW AXIAL WINDOW HANDLE (NATURAL)	HVT77-EK.810	1 pk /50 ad
	01 020811	FORZA EKSENEL PENCERE KOL YEN (BEYAZ) FORZA NEW AXIAL WINDOW HANDLE (WHITE)	HVT77-EK.811	1 pk /50 ad
	01 020812	FORZA EKSENEL PENCERE KOL YEN (RENKL) FORZA NEW AXIAL WINDOW HANDLE (COLORED)	HVT77-EK.812	1 pk /50 ad
	01 020702	FORZA EKSENEL PENCERE KOL (BEYAZ) FORZA AXIAL WINDOW HANDLE (WHITE)	HVT77-FPK.702	1 pk ./20 ad
	01 020703	FORZA EKSENEL PENCERE KOL (RENKL) FORZA AXIAL WINDOW HANDLE (COLORED)	HVT77-FPK.703	1 pk ./20 ad
	01 020803	FORZA EKSENEL PENCERE KOL (NATUREL) FORZA AXIAL WINDOW HANDLE (NATURAL)	HVT77-FPK.803	1 pk ./20 ad
		SIRIUS EKSENEL PENCERE KOLU SIRIUS CREMONE WINDOW HANDLE	H77A1154	
		SIRIUS K L TL EKSENEL PENCERE KOLU SIRIUS CREMONE WITH KEYS	H77A1160	
	01 120350	G ZL MENTE EL TEK AÇILIM SET (SA -SOL) CASEMENT SET WITH CONCEALED HINGE	HVT77-GM.350	TA İMA KAPAS TES 100 KG LOADING CAPACITY 100 KG
	01 120351	G ZL MENTE EL Ç FT AÇILIM SET (SA -SOL) CASEMENT SET WITH CONCEALED HINGE TILT-TURN SET	HVT77-GÇS.351	TA İMA KAPAS TES 100 KG LOADING CAPACITY 100 KG

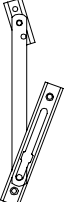
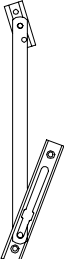
AKSESUAR ACCESSORY	STOK KODU REFERENCE CODE	AKSESUAR ADI DESCRIPTION	AKSESUAR KODU PRODUCT CODE	PAKET PACK
	01 120352	Ç FT AÇILIM SET TILT-TURN SET	HVT77-ÇS.352	TA İMA KAPAS TES MENTE E K T DE T R LEREK 90 LE 160 KG ARALI İNDA TERC H ED LEB L R. Depending on the hinge selection loading capacity can be between 90-160 kg.
	01 120353	TEK AÇILIM SET CASEMENT SET	HVT77-TS.353	TA İMA KAPAS TES MENTE E K T DE T R LEREK 65 LE 160 KG ARALI İNDA TERC H ED LEB L R. Depending on the hinge selection loading capacity can be between 65-160 kg.
	01 120286	LEVYE KOL TWO WAY SHOOTBOLT LEVER KIT	HVT77-LK.286	
	01 070201	S STEM UZUN ZAMAK SÜRGÜ (NATUREL) SYSTEM ZAMAK LATCH (NATURAL)	HVT77-FS.201	1 pk /10 ad
	01 070202	S STEM UZUN ZAMAK SÜRGÜ (BEYAZ) SYSTEM ZAMAK LATCH (WHITE)	HVT77-FS.202	1 pk /10 ad
	01 070203	S STEM UZUN ZAMAK SÜRGÜ (RENKL) SYSTEM ZAMAK LATCH (COLORED)	HVT77-FS.203	1 pk /10 ad
	01 110261	HVT77 ADAPTÖR KAPA İ HVT77 ADAPTER COVER	HVT77-ADK.325	1 Takım
	01 120210	KANAT KALDIRMA TAKOZ SASH ADJUSTING BRACKET	HVT77-KST.210	1 pk / 50 ad
	01 080301	S STEM 13 CM VAS STAS MAKAS (ELOKSALLI) SYSTEM 13 CM TRANSOM TRUSS (ANODIZED)	HVT77-VM.301	1 pk /50 ad
	01 080302	S STEM 13 CM VAS STAS MAKAS (BEYAZ) SYSTEM 13 CM TRANSOM TRUSS (WHITE)	HVT77-VM.302	1 pk /50 ad
	01 080303	S STEM 13 CM VAS STAS MAKAS (RENKL) SYSTEM 13 CM TRANSOM TRUSS (COLORED)	HVT77-VM.303	1 pk /50 ad
	01 080401	S STEM 22 CM VAS STAS MAKAS (ELOKSALLI) SYSTEM 22 CM TRANSOM TRUSS (ANODIZED)	HVT77-VM.401	1 pk /50 ad
	01 080402	S STEM 22 CM VAS STAS MAKAS (BEYAZ) SYSTEM 22 CM TRANSOM TRUSS (WHITE)	HVT77-VM.402	1 pk /50 ad
	01 080403	S STEM 22 CM VAS STAS MAKAS (RENKL) SYSTEM 22 CM TRANSOM TRUSS (COLORED)	HVT77-VM.403	1 pk /50 ad

AKSESUAR ACCESSORY	STOK KODU REFERENCE CODE	AKSESUAR ADI SYSTEM TRANSOM CATCH (CLOSED) DESCRIPTION	AKSESUAR KODU PRODUCT CODE	PAKET PACK
	01 081702	S STEM AYARLI VAS STAS ÇARPMA (NATUREL) SYSTEM TRANSOM CATCH (NATURAL)	HVT77-VÇ.702	1 pk /100 ad
	01 081703	S STEM AYARLI VAS STAS ÇARPMA (BEYAZ) SYSTEM TRANSOM CATCH (WHITE)	HVT77-VÇ.703	1 pk /100 ad
	01 081704	S STEM AYARLI VAS STAS ÇARPMA (RENKL) SYSTEM TRANSOM CATCH (COLORED)	HVT77-VÇ.704	1 pk /100 ad
	01 120214	CAM YAN DESTEK TAKOZ GLAZING WEDGE (SIDE)	HVT77-CT.214	1 pk / 20 ad
	01 120215	CAM ALTI DESTEK TAKOZ (SAB T PANELLER Ç N) GLAZING WEDGE (BOTTOM) FOR FIXED PANELS	HVT77-CT.215	1 pk /20 ad
	04 010115	SAB T PERDEL YA MUR TAHL YE KAPAK WATER DRAIN COVER (FIXED)	HVT77-TK.115	1 pk / 1000 ad
	04 010112	HAREKETL PERDEL YA MUR TAHL YE KAPAK WATER DRAIN COVER (MOVEABLE)	HVT77-TK.112	1 pk / 1000 ad
	01 120211	KANAT Ç KÖ E GÖNYE CORNER BRACKET	HVT77-KG.149	1 pk / 500 ad
	01 120212	KANAT DI KÖ E GÖNYE CORNER BRACKET	HVT77-KG.178	1 pk / 500 ad
	01 120213	KANAT Ç KÖ E GÖNYE CORNER BRACKET	HVT77-KG.206	1 pk / 500 ad
	11 010206	CAM YAN DESTEK TAKOZ V DASI (M3.9x38 mm YSB M.U.V) 3.9x38 mm SELF DRILLING SCREW	HVT77-SC.206	1 pk / 1000 ad
	11 010201	CAM YAN DESTEK TAKOZ V DASI (M3.9x16 mm YSB M.U.V) 3.9x16 mm SELF DRILLING SCREW	HVT77-SC.201	1 pk / 1000 ad
	11 010200	CAM YAN DESTEK TAKOZ V DASI (M3.9x13 mm YSB M.U.V) 3.9x13 mm SELF DRILLING SCREW	HVT77-SC.200	1 pk / 1000 ad
	08 030160	EPDM 600 ml. SOS S EPDM SEALANT 600 ml.	HVT77-SM.160	1 pk /12 ad

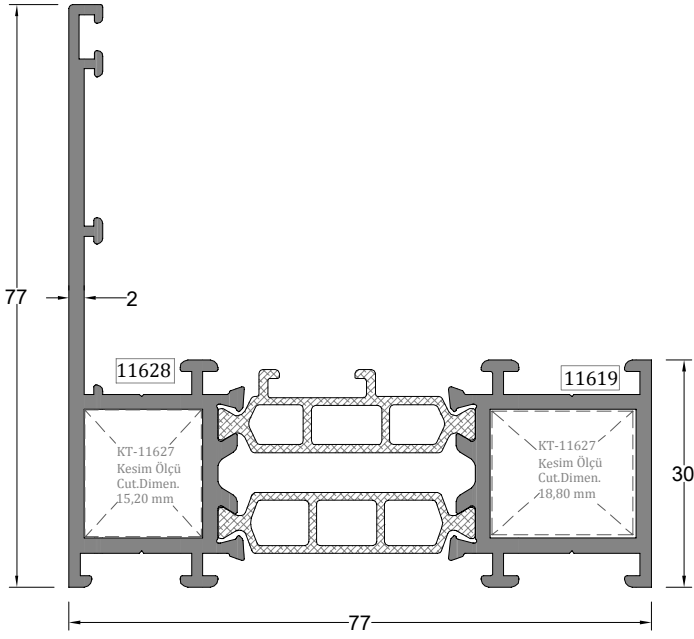

Kasa Profili FRAME PROFILE	Profil Kodu Profile Code	(kg/mt) Weight	Jx cm ⁴	Jy cm ⁴
	77-11619-11628	1,727	18,58	45,68

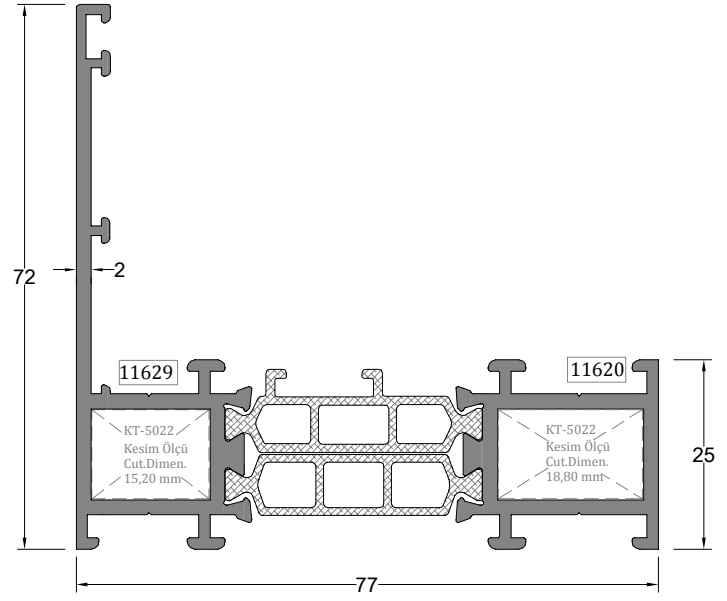

Kasa Profili FRAME PROFILE	Profil Kodu Profile Code	(kg/mt) Weight	Jx cm ⁴	Jy cm ⁴
	77-11620-11629	1,617	15,18	41,99

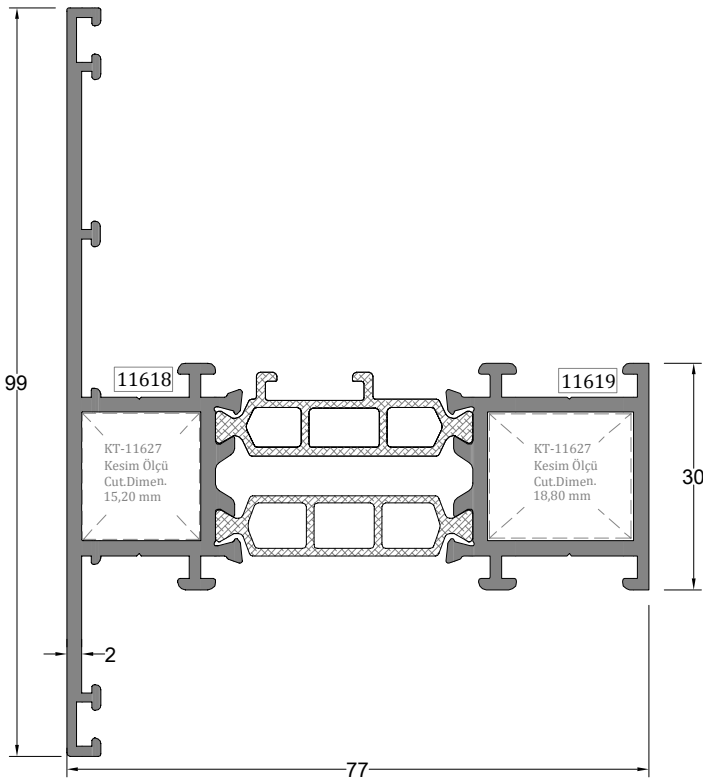

Orta Kayıt Profili MULLION PROFILE	Profil Kodu Profile Code	(kg/mt) Weight	Jx cm ⁴	Jy cm ⁴
	77-11618-11619	1,869	24,10	49,84

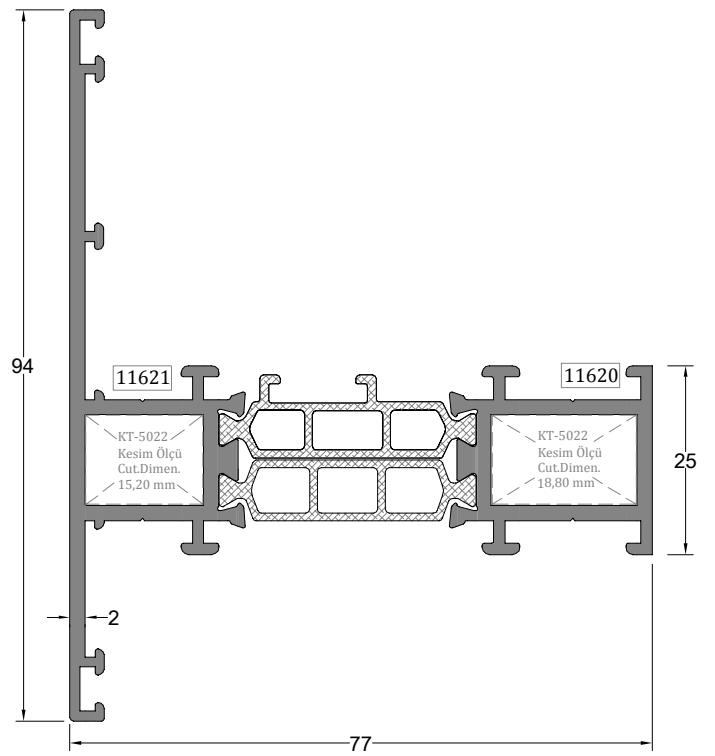

Orta Kayıt Profili MULLION PROFILE	Profil Kodu Profile Code	(kg/mt) Weight	Jx cm ⁴	Jy cm ⁴
	77-11620-11621	1,754	19,95	45,98

** Her profil için minimum sipariş 300 kg'dır.
** Minimum order quantity is 300 kg per profile.

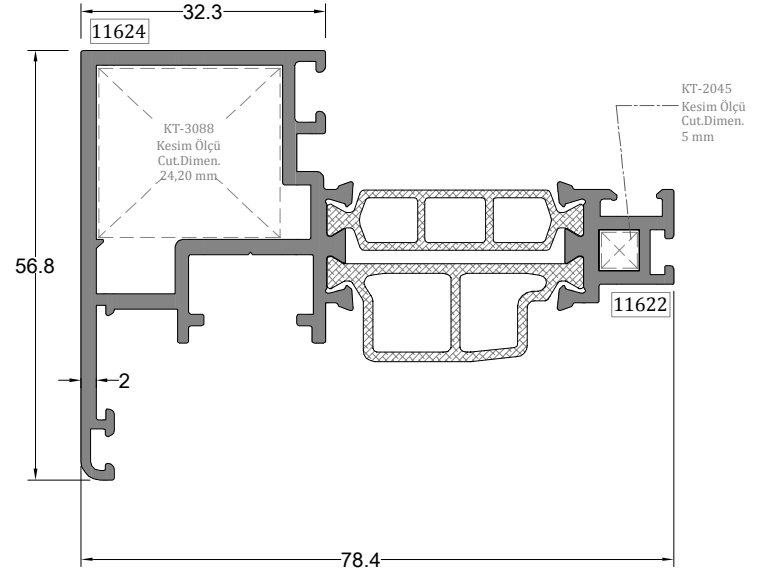
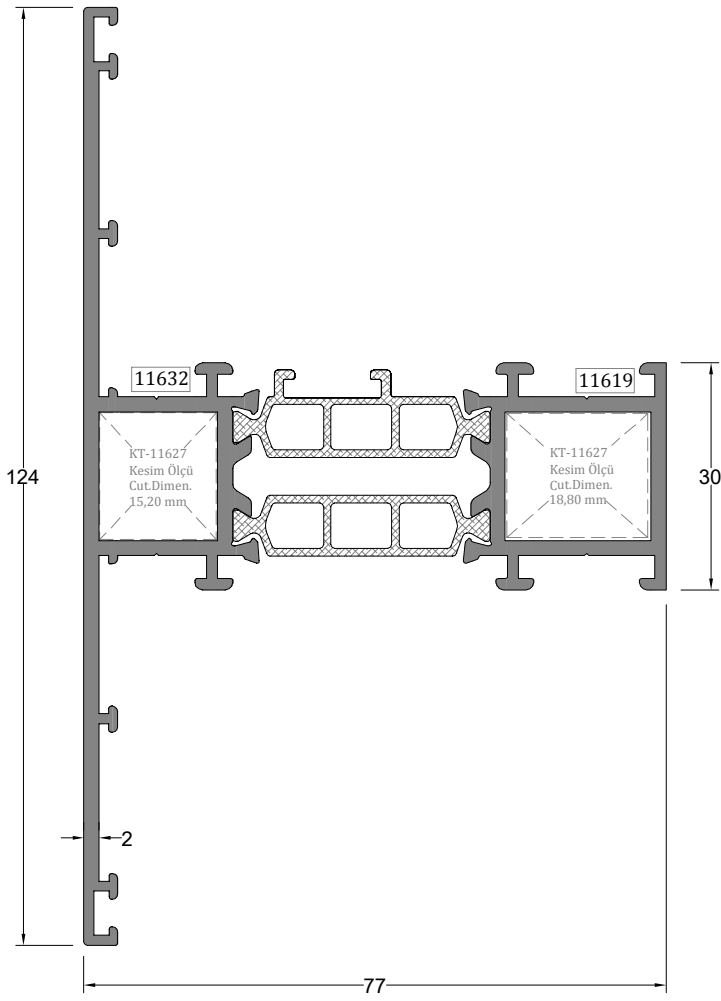

Orta Kayıt Profili MULLION PROFILE	Profil Kodu Profile Code	(kg/mt) Weight	Jx cm ⁴	Jy cm ⁴
	77-11619-11632	2,014	39,67	53,69

Kanat Profili SASH PROFILE	Profil Kodu Profile Code	(kg/mt) Weight	Jx cm ⁴	Jy cm ⁴
	77-11622-11624	1,454	8,45	30,77

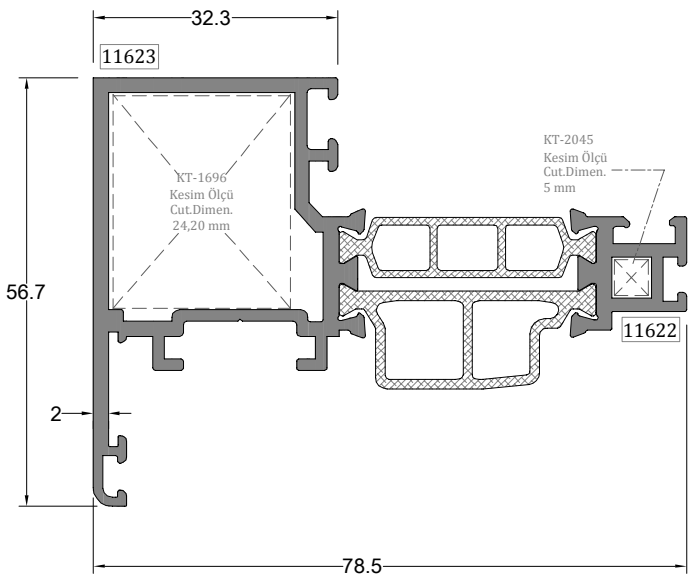

Kanat Profili SASH PROFILE	Profil Kodu Profile Code	(kg/mt) Weight	Jx cm ⁴	Jy cm ⁴
	77-11623-11622	1,501	8,64	30,83

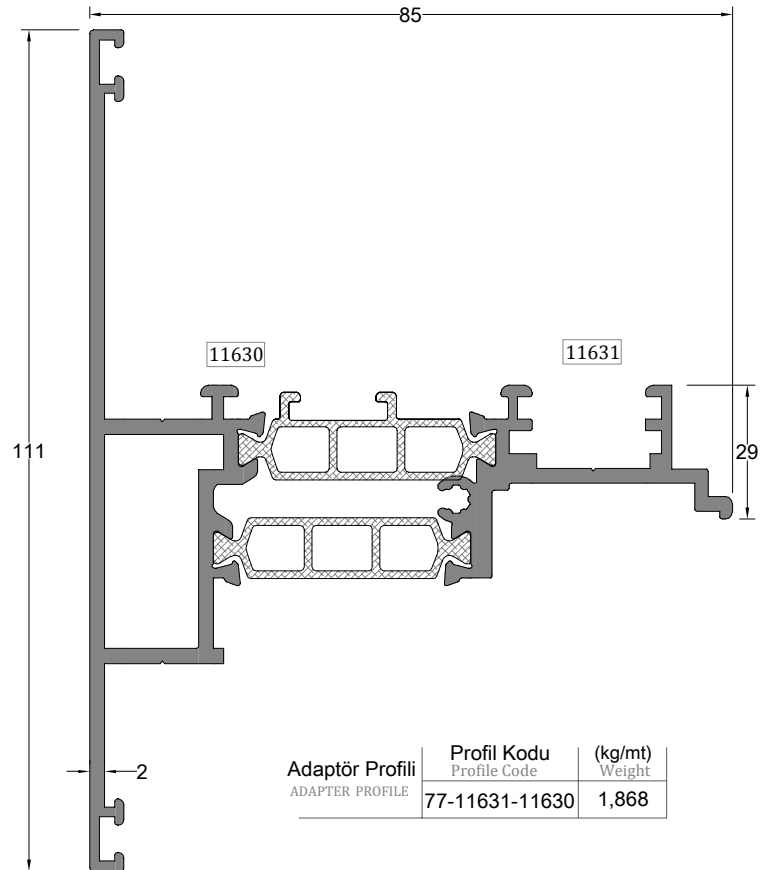

Adaptör Profili ADAPTER PROFILE	Profil Kodu Profile Code	(kg/mt) Weight
	77-11631-11630	1,868

** Her profil için minimum sipariş 300 kg'dır.
** Minimum order quantity is 300 kg per profile.

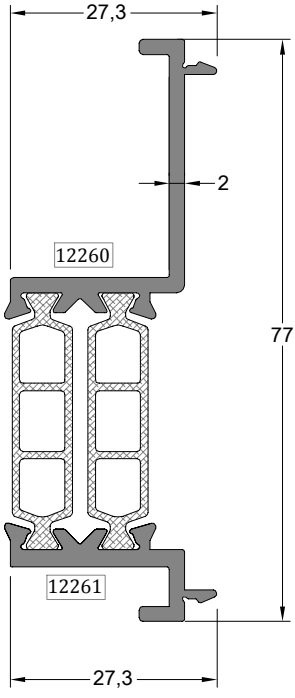

Cepheye Geçiř Adaptör Profili	Profil Kodu Profile Code	(kg/mt) Weight
ADAPTER PROFILE	77-12260-12261	1,407

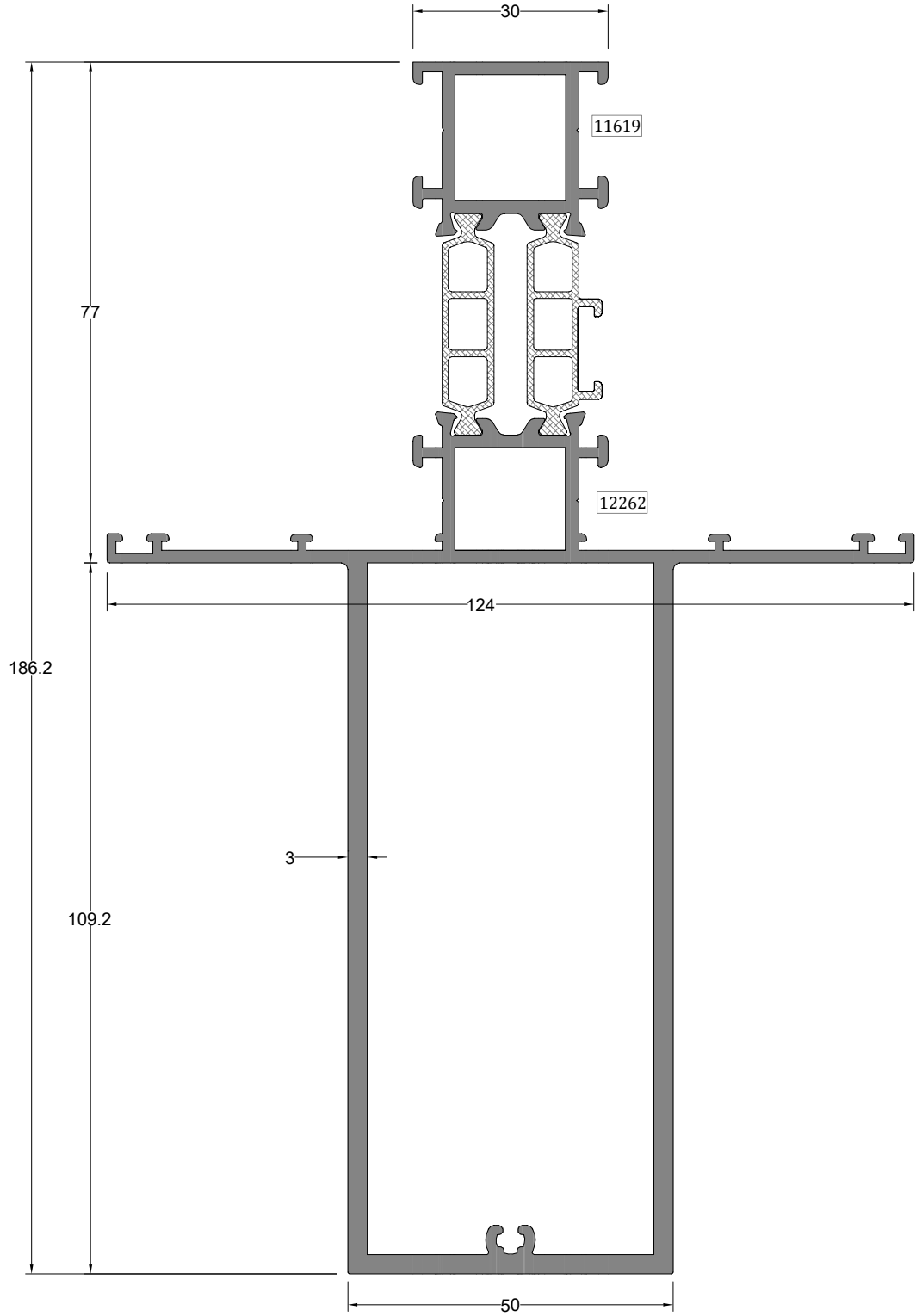

Takviyeli Orta Kayıt Profili	Profil Kodu Profile Code	(kg/mt) Weight	Jx cm ⁴	Jy cm ⁴
REINFORCED MULLION PROFILE	77-11619-12262	4,206	451,25	79,11

** Her profil için minimum sipariş 300 kg'dır.
** Minimum order quantity is 300 kg per profile.

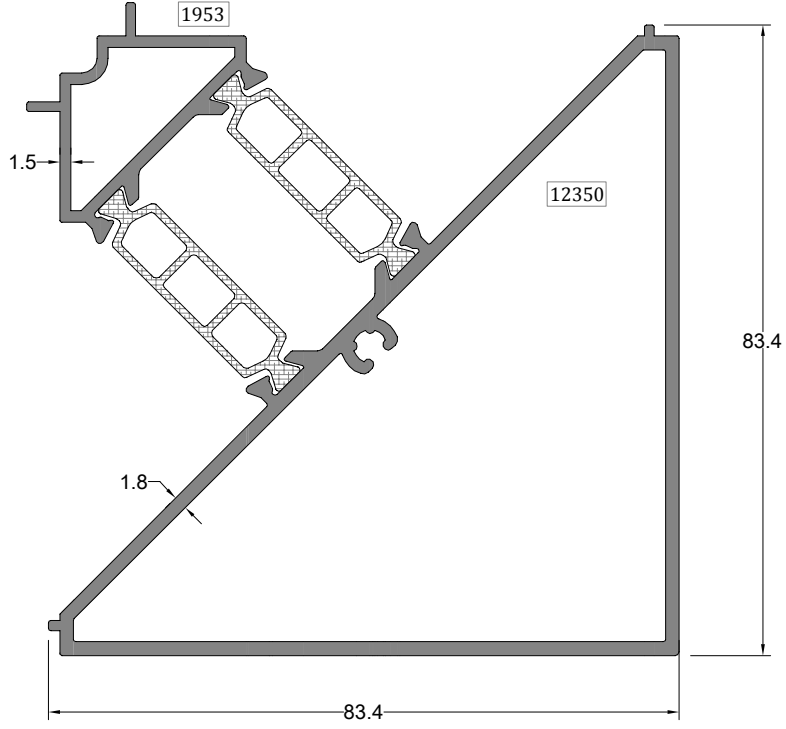

Köşe Dönüş Profili CORNER PROFILE	Profil Kodu Profile Code	(kg/mt) Weight	Jx cm ⁴	Jy cm ⁴
	77-12350-1953	2,188	59,38	59,38

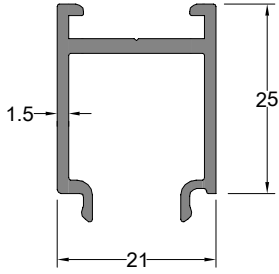

Cam Yükseltme Çıtası GLAZING ELEVATION BEAD	Profil Kodu Profile Code	(kg/mt) Weight
	11617	0,359

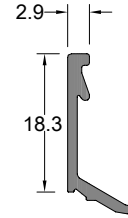

Cam Çıtası GLAZING BEAD	Profil Kodu Profile Code	(kg/mt) Weight
	11616	0,117

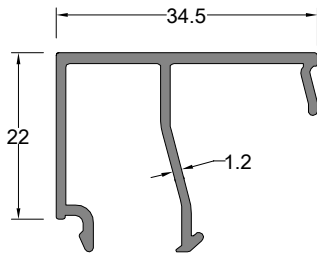

Cam Çıtası GLAZING BEAD	Profil Kodu Profile Code	(kg/mt) Weight
	1747	0,340

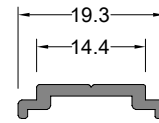

Tij Profili STEM BAR PROFILE	Profil Kodu Profile Code	(kg/mt) Weight
	8241	0,099

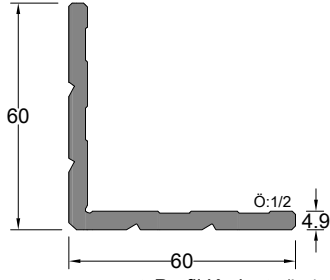

Köşe takozu CORNER WEDGE PROFILE	Profil Kodu Profile Code	(kg/mt) Weight
	2045	1,436

Köşe Takozu Profil Kodu Corner Wedge Profile Code	Kullanıldığı Profil Compatible Profile	Kesim Boyu (mm) Cutting Length(mm)
2045	11622	5,00 mm

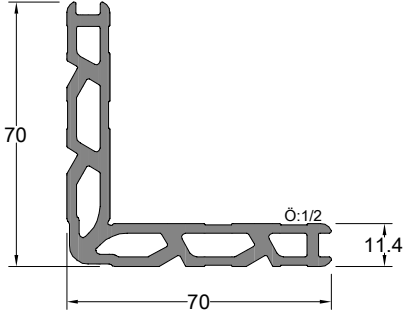

Köşe takozu CORNER WEDGE PROFILE	Profil Kodu Profile Code	(kg/mt) Weight
	5022	2,245

Köşe Takozu Profil Kodu Corner Wedge Profile Code	Kullanıldığı Profil Compatible Profile	Kesim Boyu (mm) Cutting Length(mm)
5022	11620	18,80 mm
	11621	15,20 mm
	11629	15,20 mm

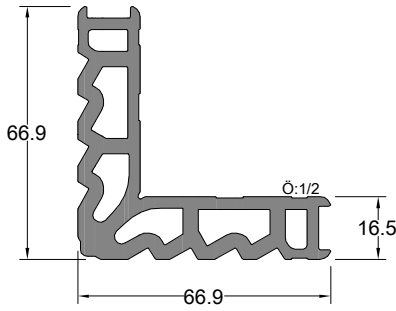

Köşe takozu CORNER WEDGE PROFILE	Profil Kodu Profile Code	(kg/mt) Weight
	11627	2,929

Köşe Takozu Profil Kodu Corner Wedge Profile Code	Kullanıldığı Profil Compatible Profile	Kesim Boyu (mm) Cutting Length(mm)
11627	11619	18,80 mm
	11618	15,20 mm
	11628	15,20 mm
	11632	15,20 mm

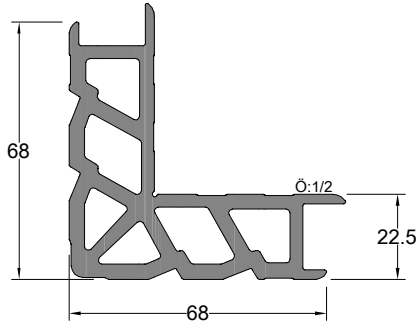

Köşe takozu CORNER WEDGE PROFILE	Profil Kodu Profile Code	(kg/mt) Weight
	3088	3,480

Köşe Takozu Profil Kodu Corner Wedge Profile Code	Kullanıldığı Profil Compatible Profile	Kesim Boyu (mm) Cutting Length(mm)
3088	11624	24,20 mm

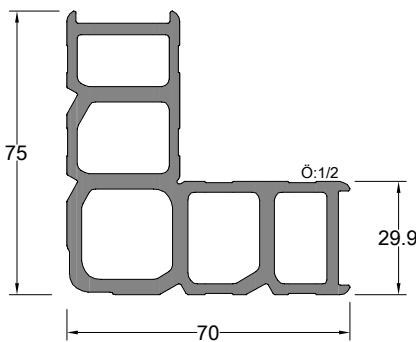

Köşe takozu CORNER WEDGE PROFILE	Profil Kodu Profile Code	(kg/mt) Weight
	1696	3,340

Köşe Takozu Profil Kodu Corner Wedge Profile Code	Kullanıldığı Profil Compatible Profile	Kesim Boyu (mm) Cutting Length(mm)
1696	1623	24,20 mm

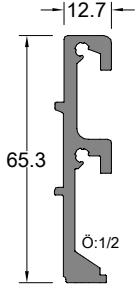

Orta Kayıt Bağlantı Profili MULLION CONNECTION PROFILE	Profil Kodu Profile Code	(kg/mt) Weight
	11625	0,990

Dik Bağlantı Kodu	Kullanıldığı Profil	Kesim ölçüsü	Kesit
11625	12262	16,5 mm	
	11632	16,5 mm	

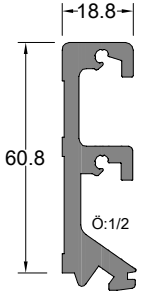

Orta Kayıt Bağlantı Profili MULLION CONNECTION PROFILE	Profil Kodu Profile Code	(kg/mt) Weight
	11626	1,502

Dik Bağlantı Kodu	Kullanıldığı Profil	Kesim ölçüsü	Kesit
11626	11619	16,5 mm	

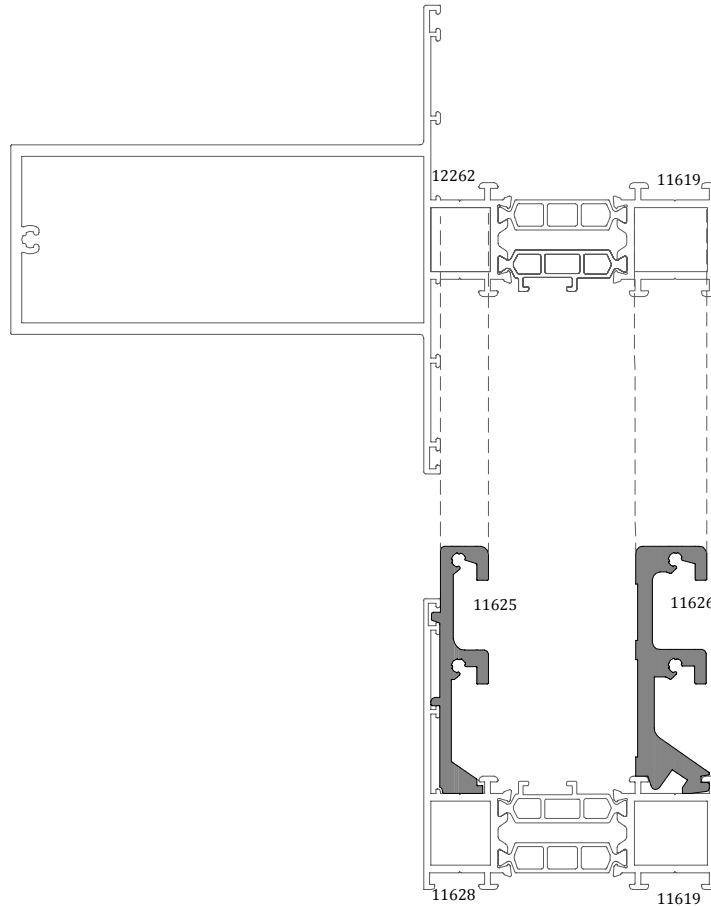

Ö:1/2

CAM KALINLIĞI GLAZING THICKNESS	KANATLAR İÇİN (FOR SASH)		SABİTLER İÇİN (FOR FIXED)		CAM ÇİTASI GLAZING BEAD	CAM ÇİTASI UZUNLUĞU GLAZING BEAD LENGTH
	(F1)	(O1)	(F2)	(O2)		
24 mm	CF.15	GKF.67	CF.40	DCF.30	3537	41,5 mm
26 mm	CF.13	GKF.67	CF.50	DCF.30	1749	38,5 mm
28 mm	CF.11	GKF.67	CF.30	DCF.30	1749	38,5 mm
30 mm	CF.80	GKF.67	CF.50	DCF.30	1747	34,5 mm
30.8 mm	CF.80	GKF.67	CF.50	DCF.30	1747	34,5 mm
32 mm	CF.07	GKF.67	CF.30	DCF.30	1747	34,5 mm
34 mm	CF.05	GKF.67	CF.40	DCF.30	3536	31,5 mm
36 mm	CF.03	GKF.67	CF.40	DCF.30	3636	29,5 mm

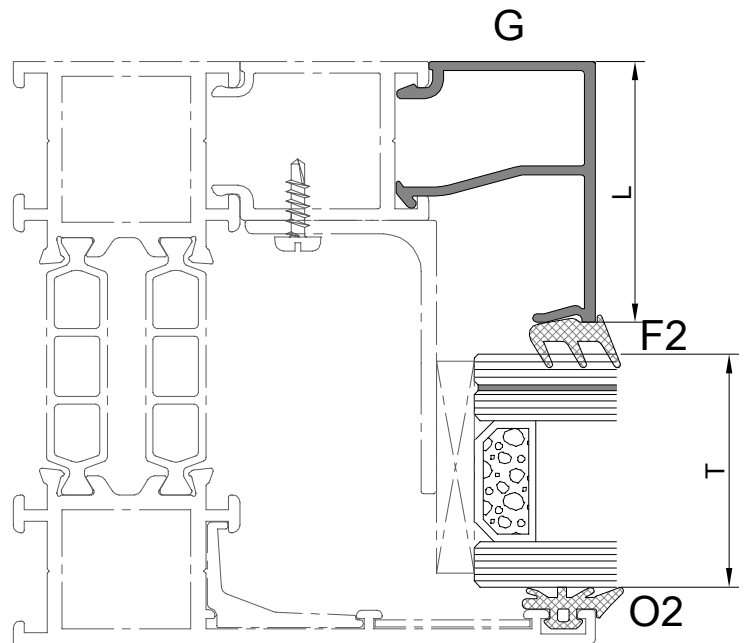
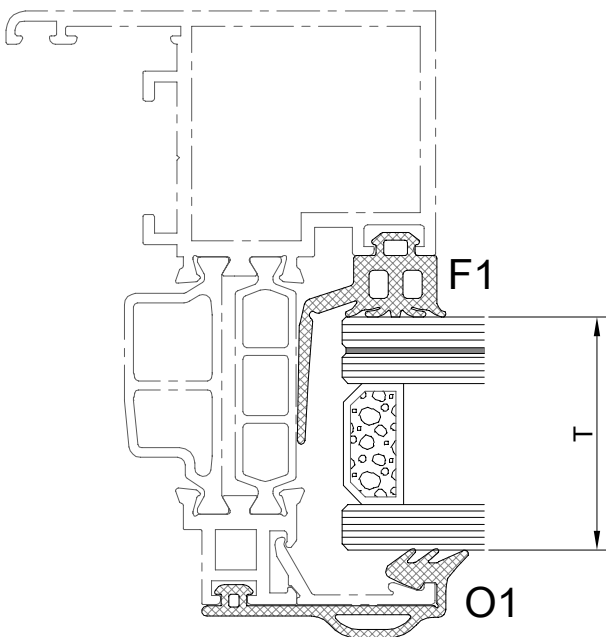

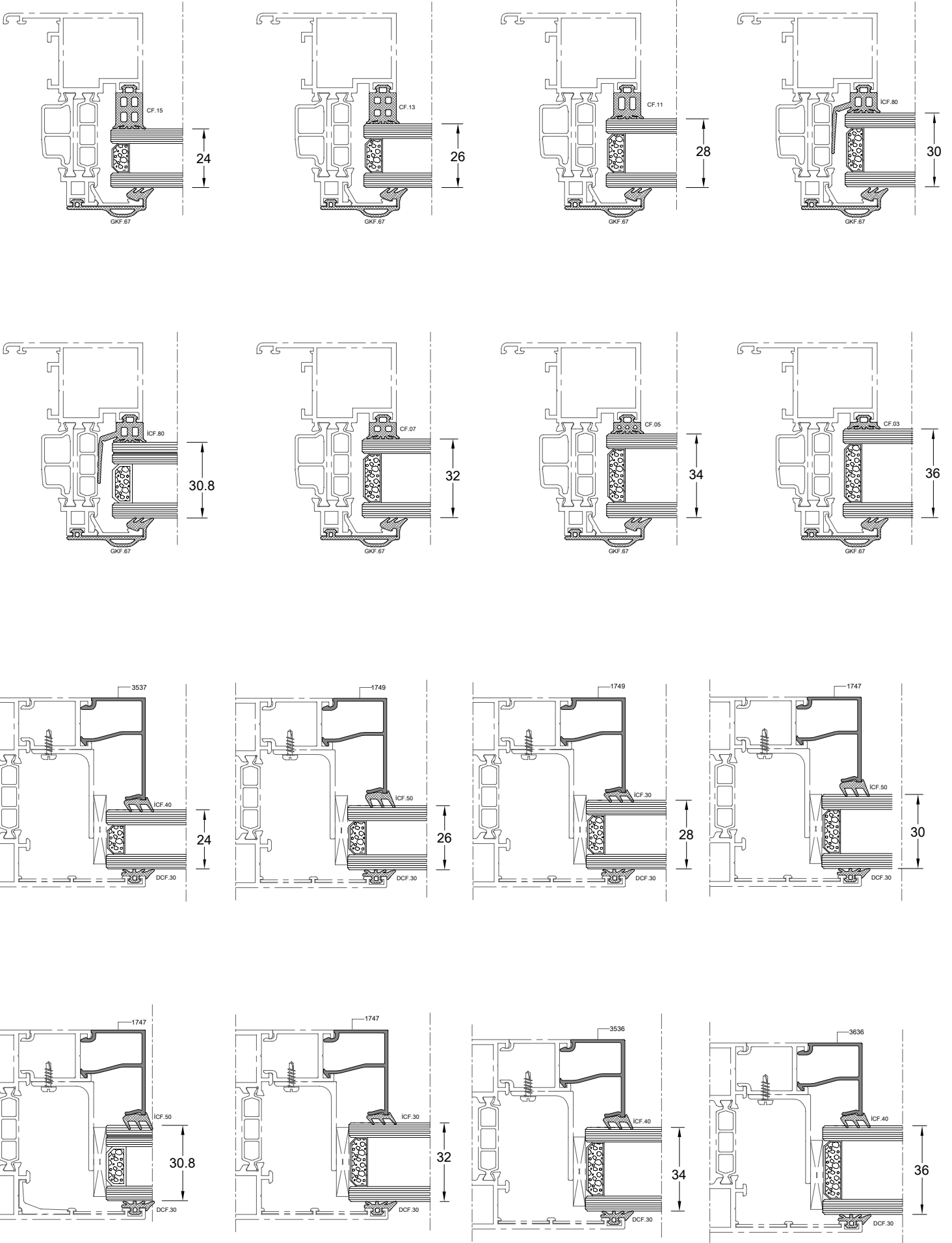

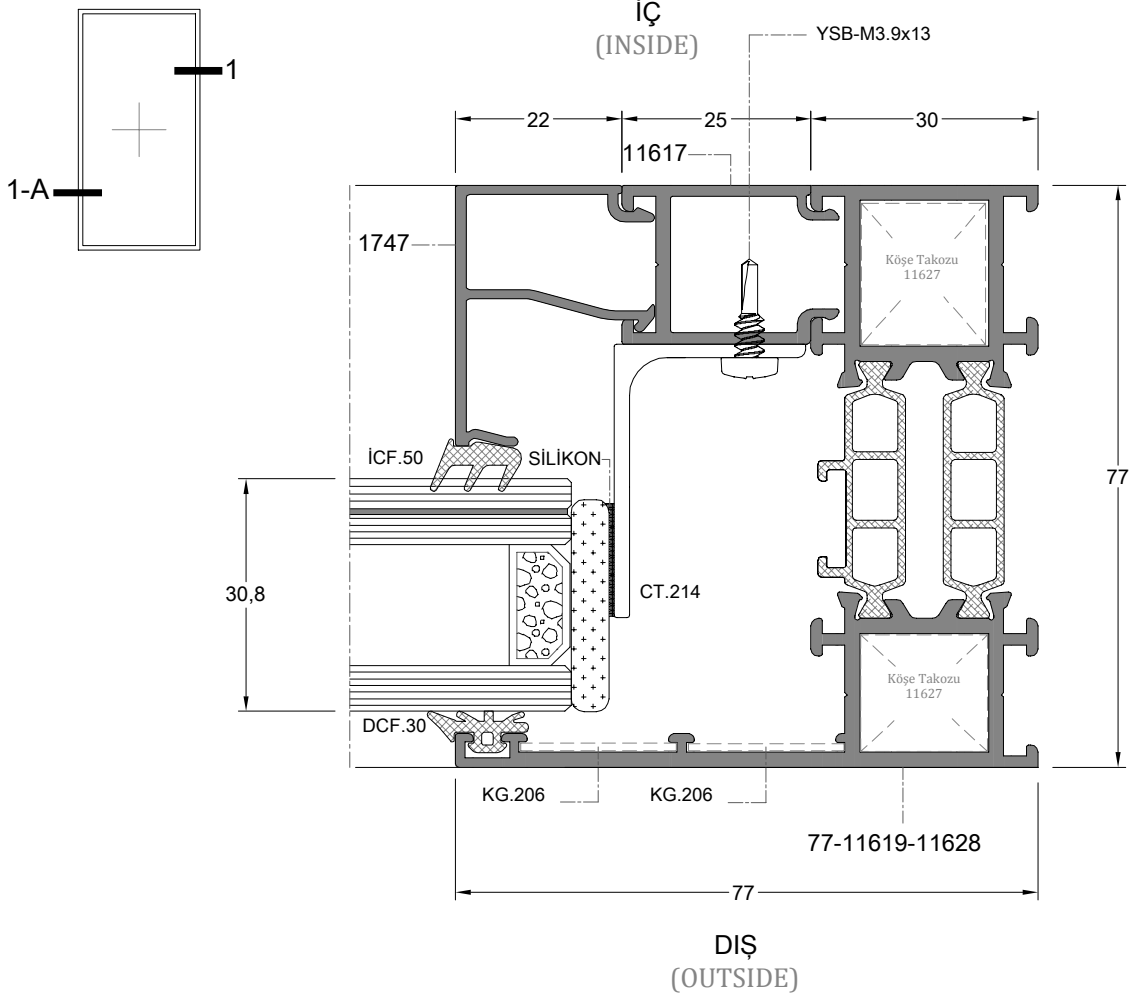

D-1

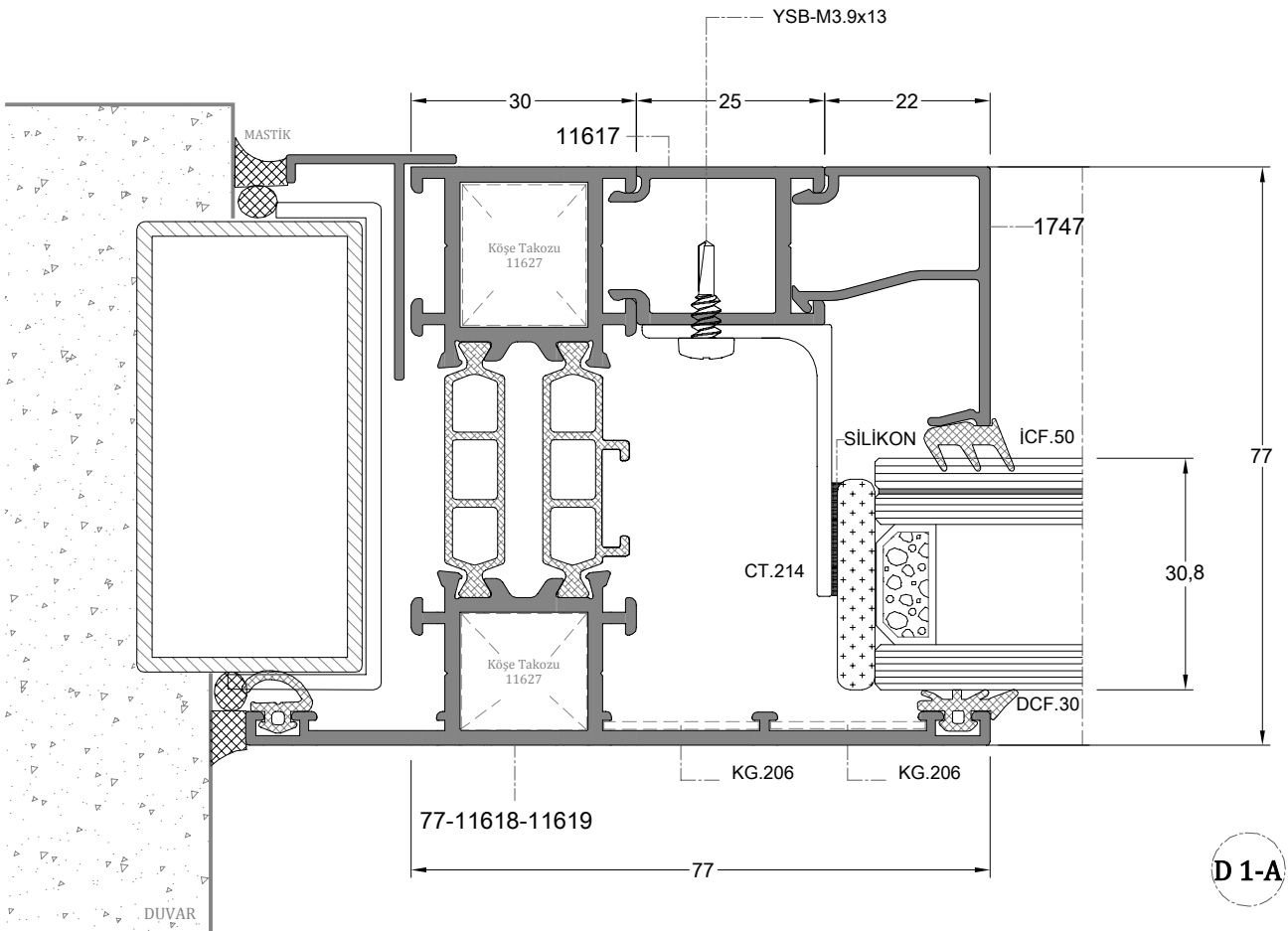

D 1-A

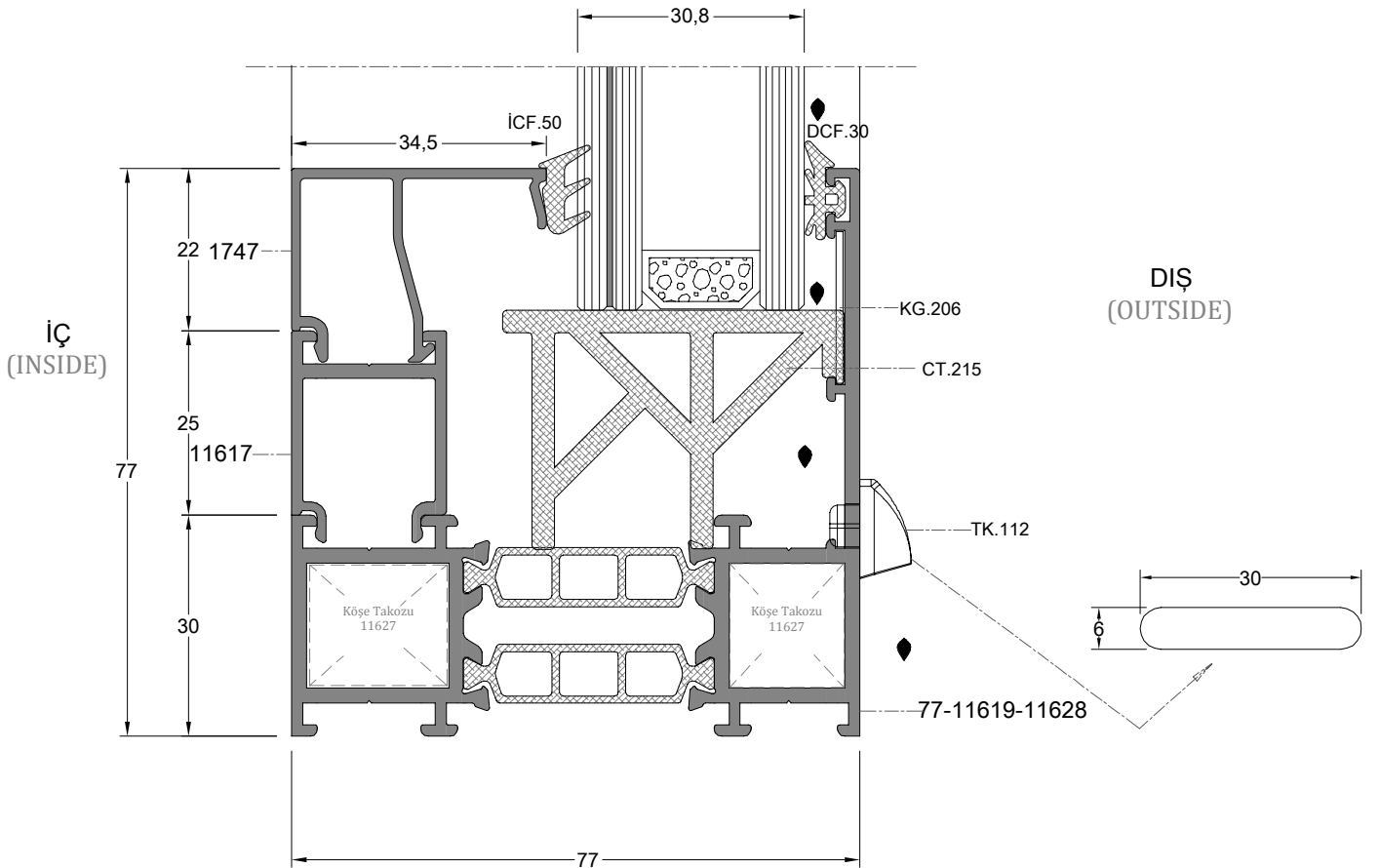
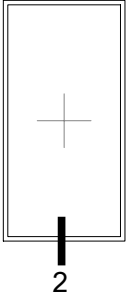

D-2

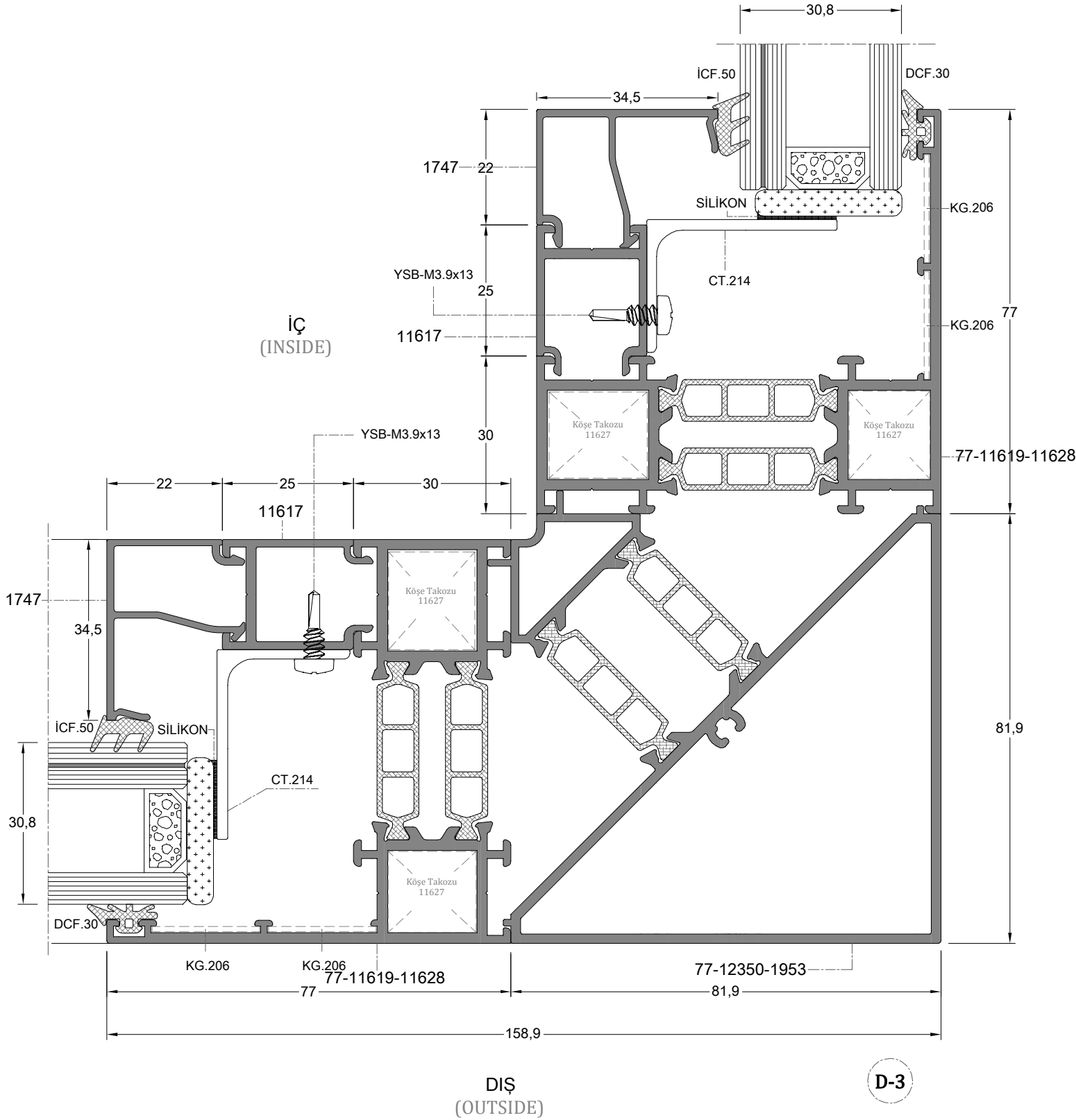
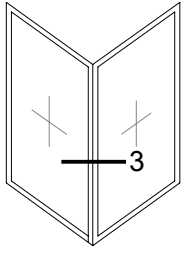

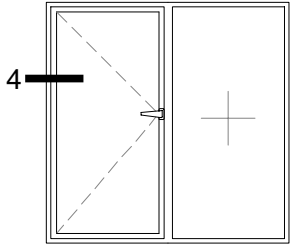

İÇ
(INSIDE)

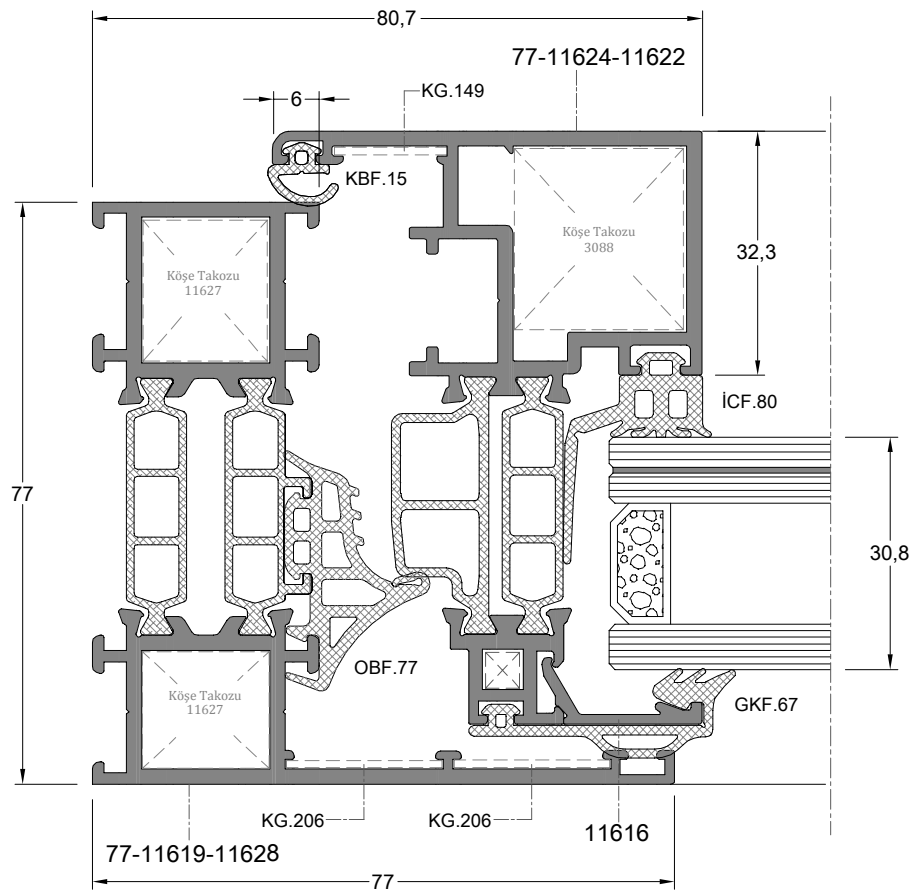

DIŞ
(OUTSIDE)

D-4

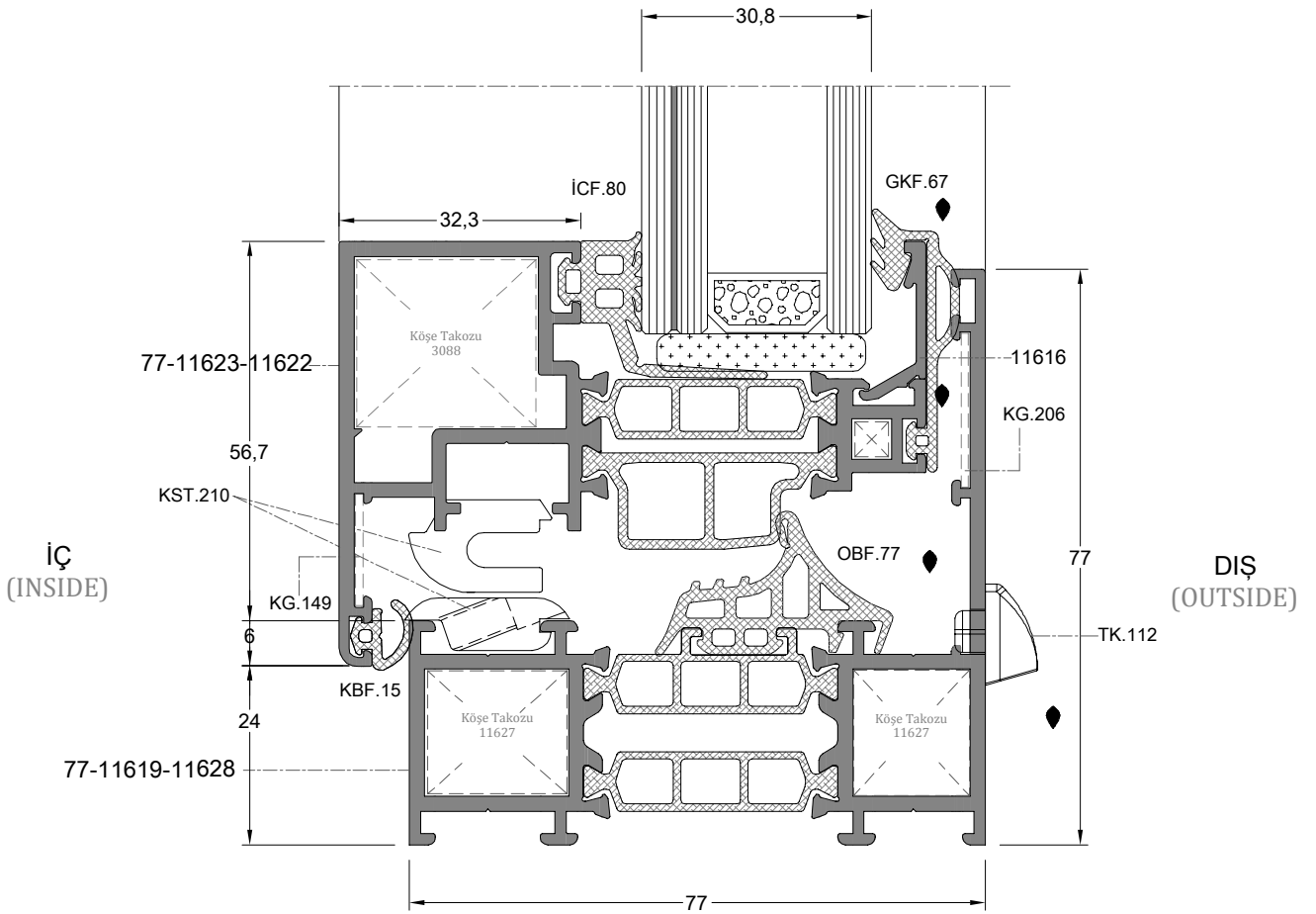
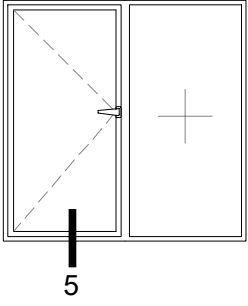

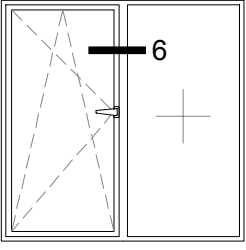

İÇ
(INSIDE)

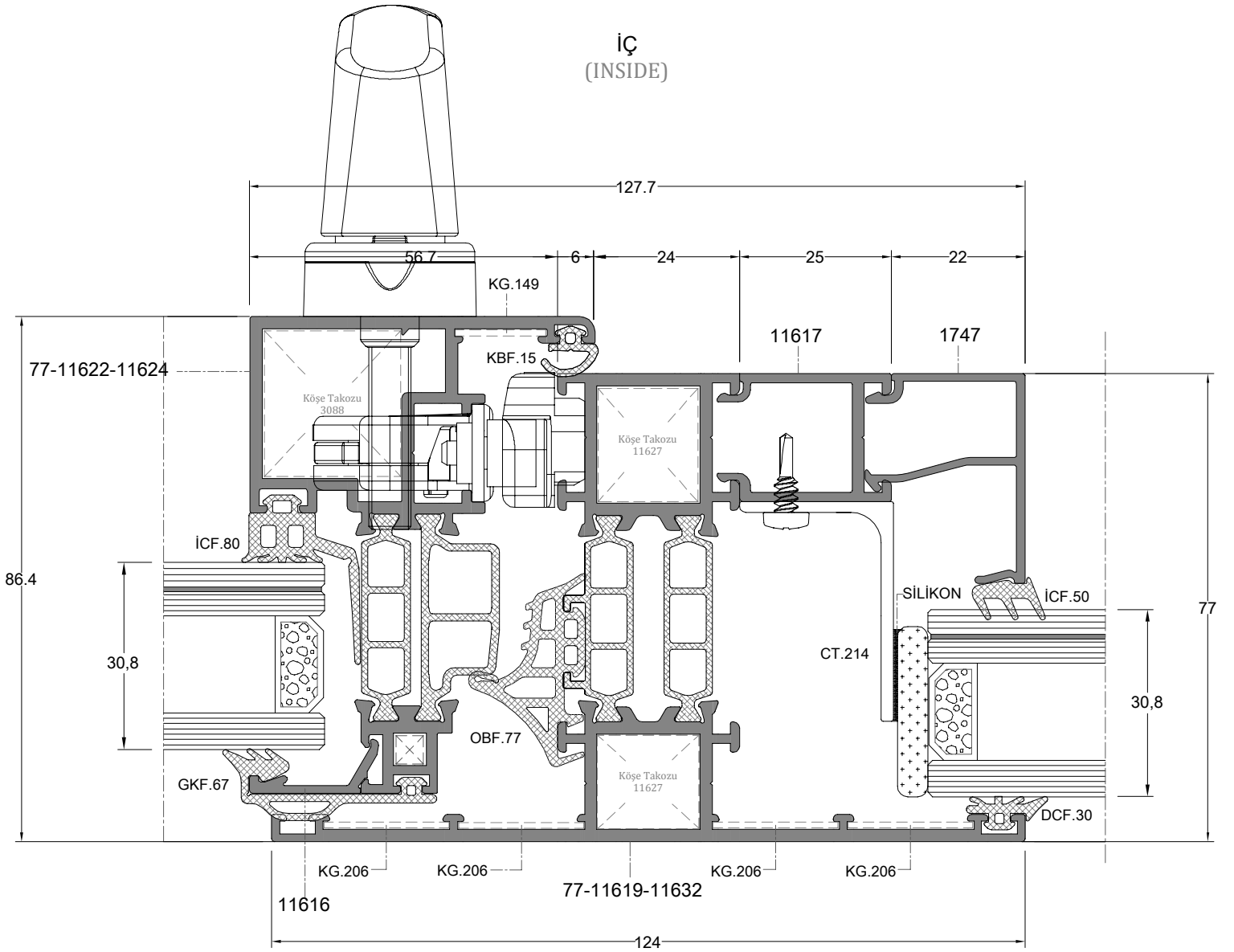

DIŞ
(OUTSIDE)

D-6

İÇ
(INSIDE)

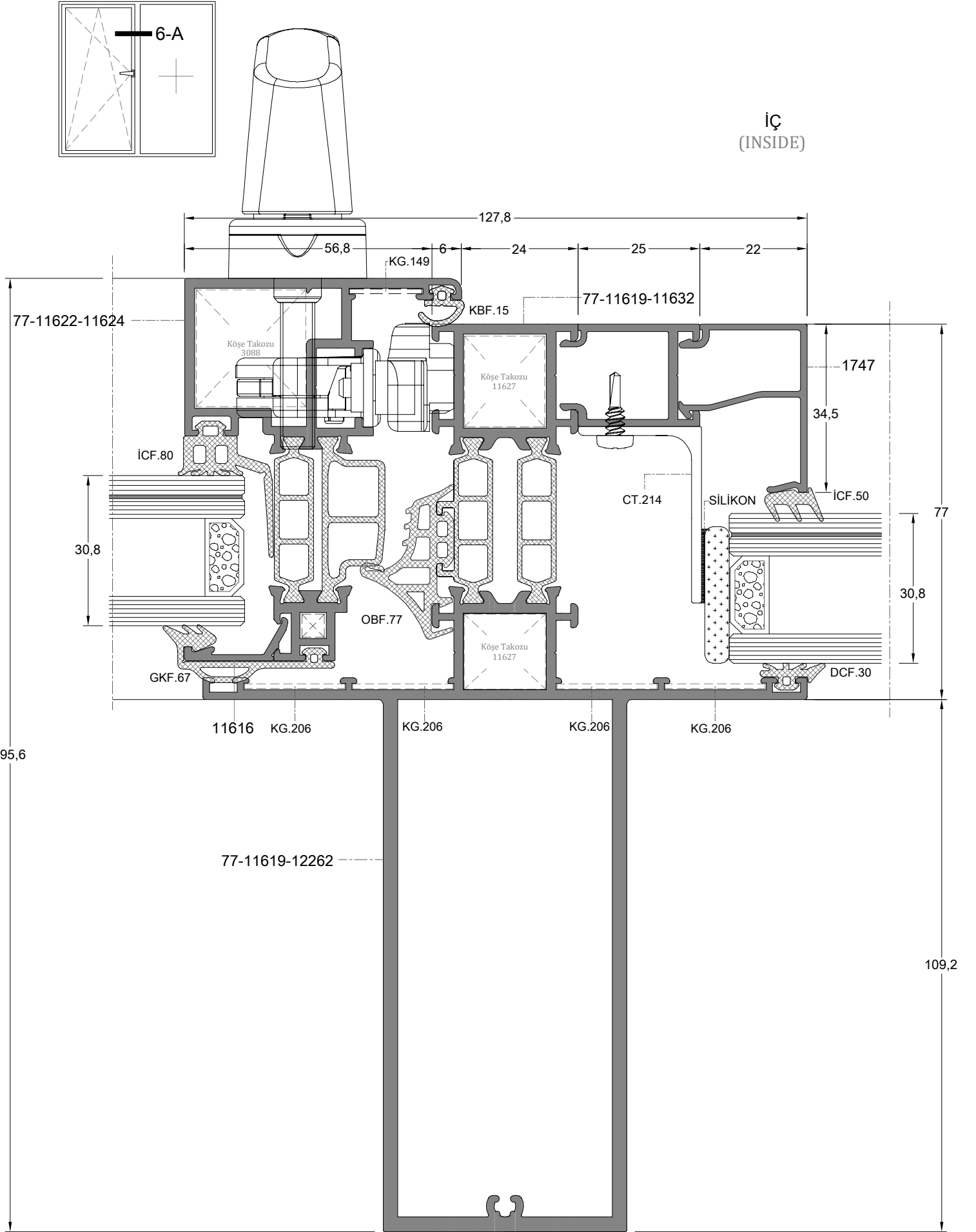

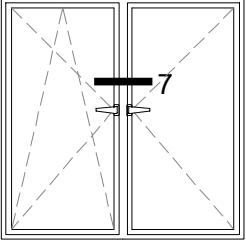

HEMİYÜZ ÇE AÇILIR ADAPTÖRLÜ DETAY
SYMMETRICAL INWARD OPENING DETAIL WITH ADAPTER

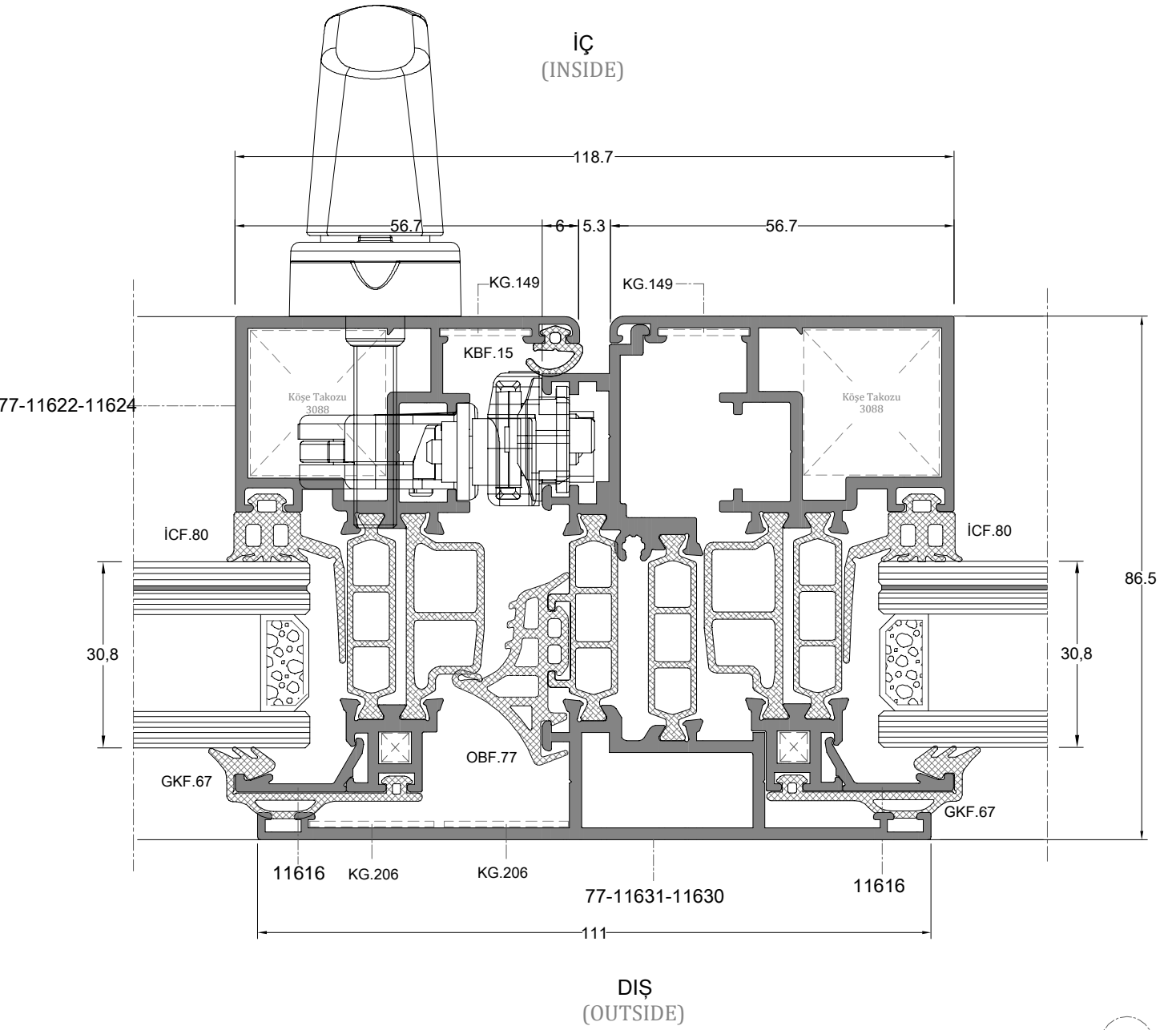

D-7

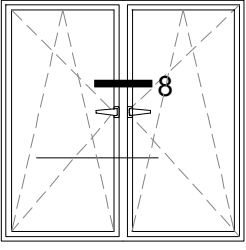

B N L ÇE AÇILIR ORTA KAYITLI DETAY
OVERLAPPING INWARD OPENING DETAIL WITH MULLION

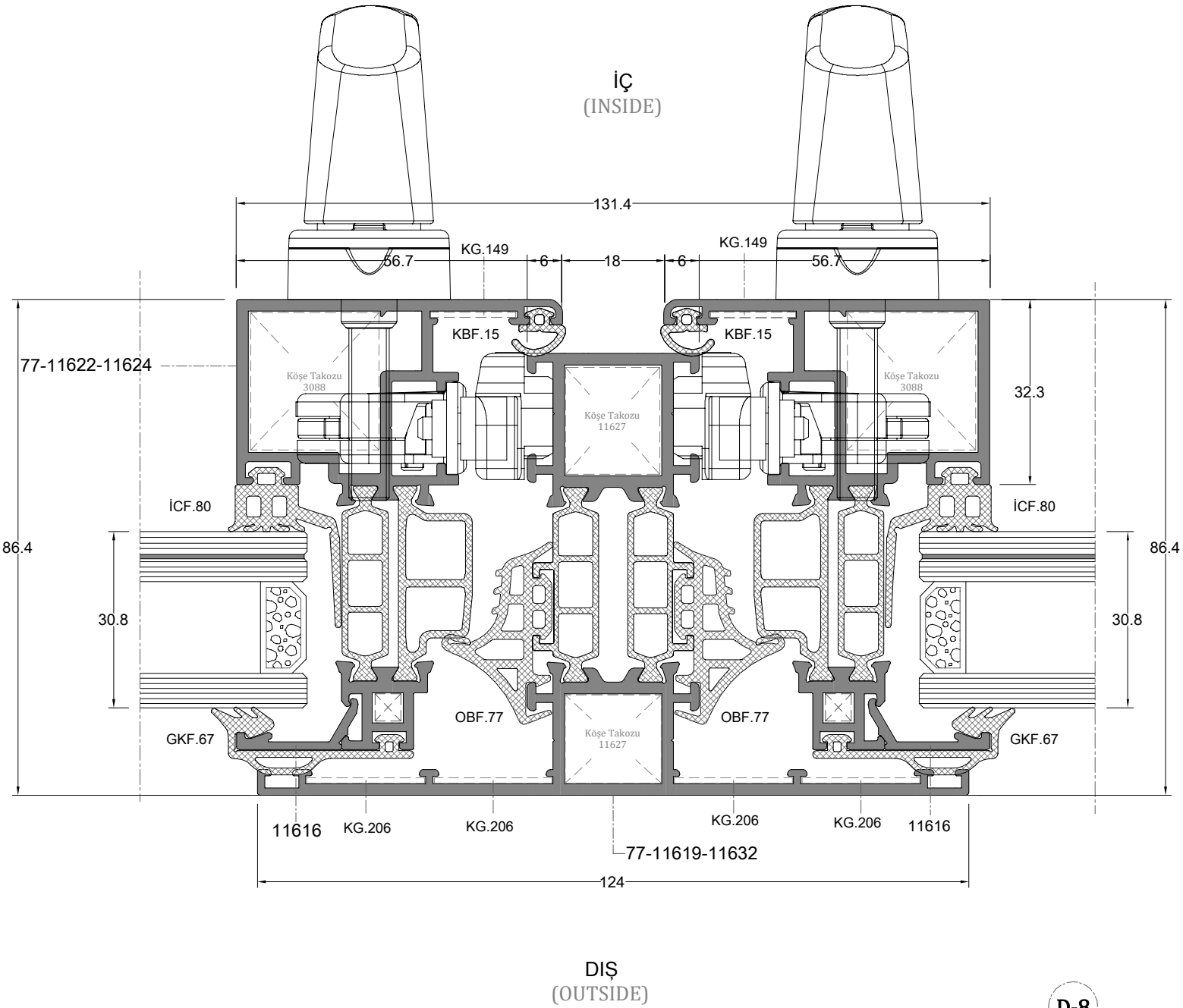

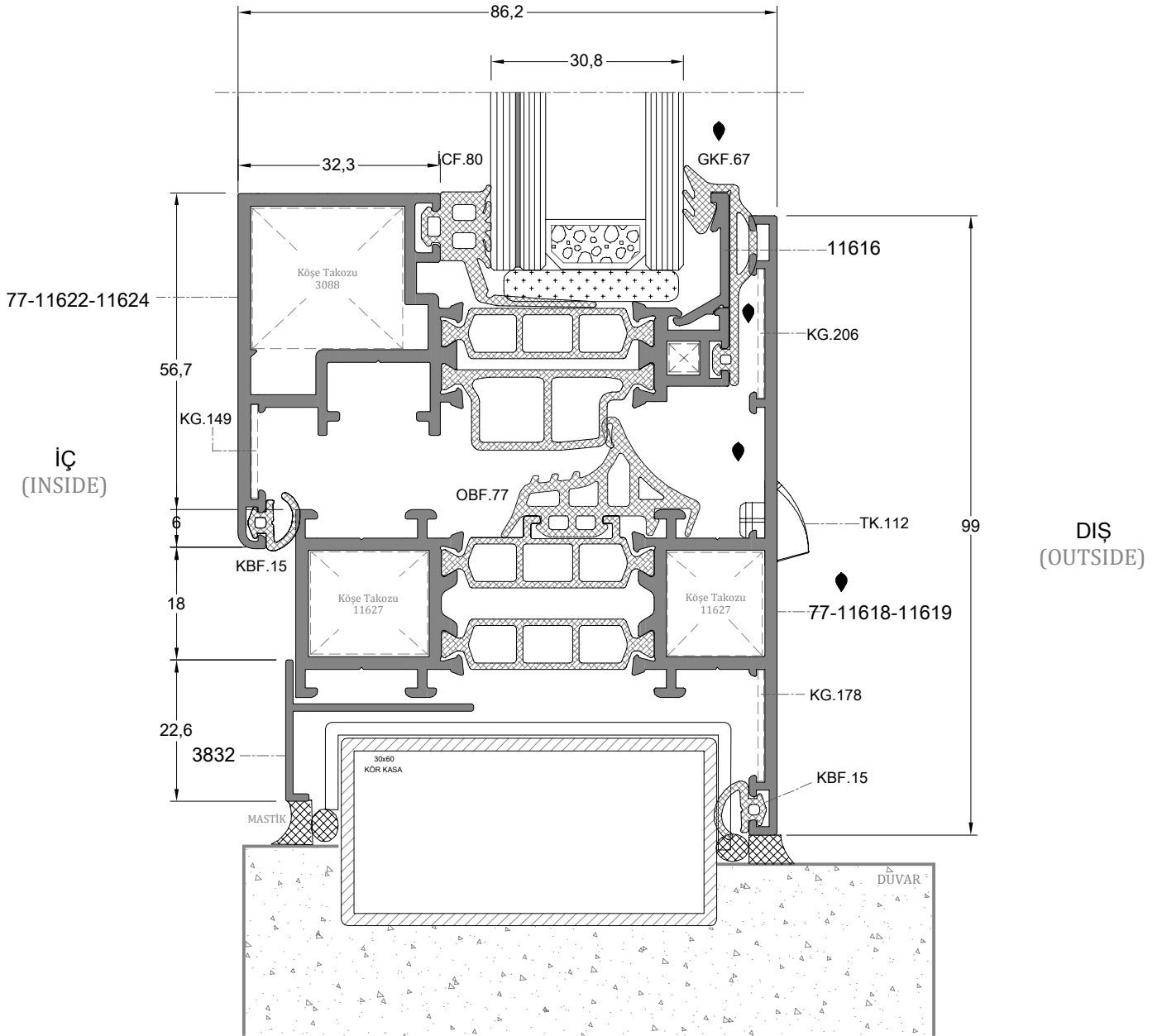
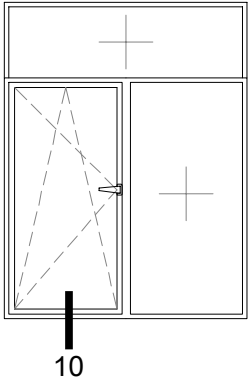

D-10

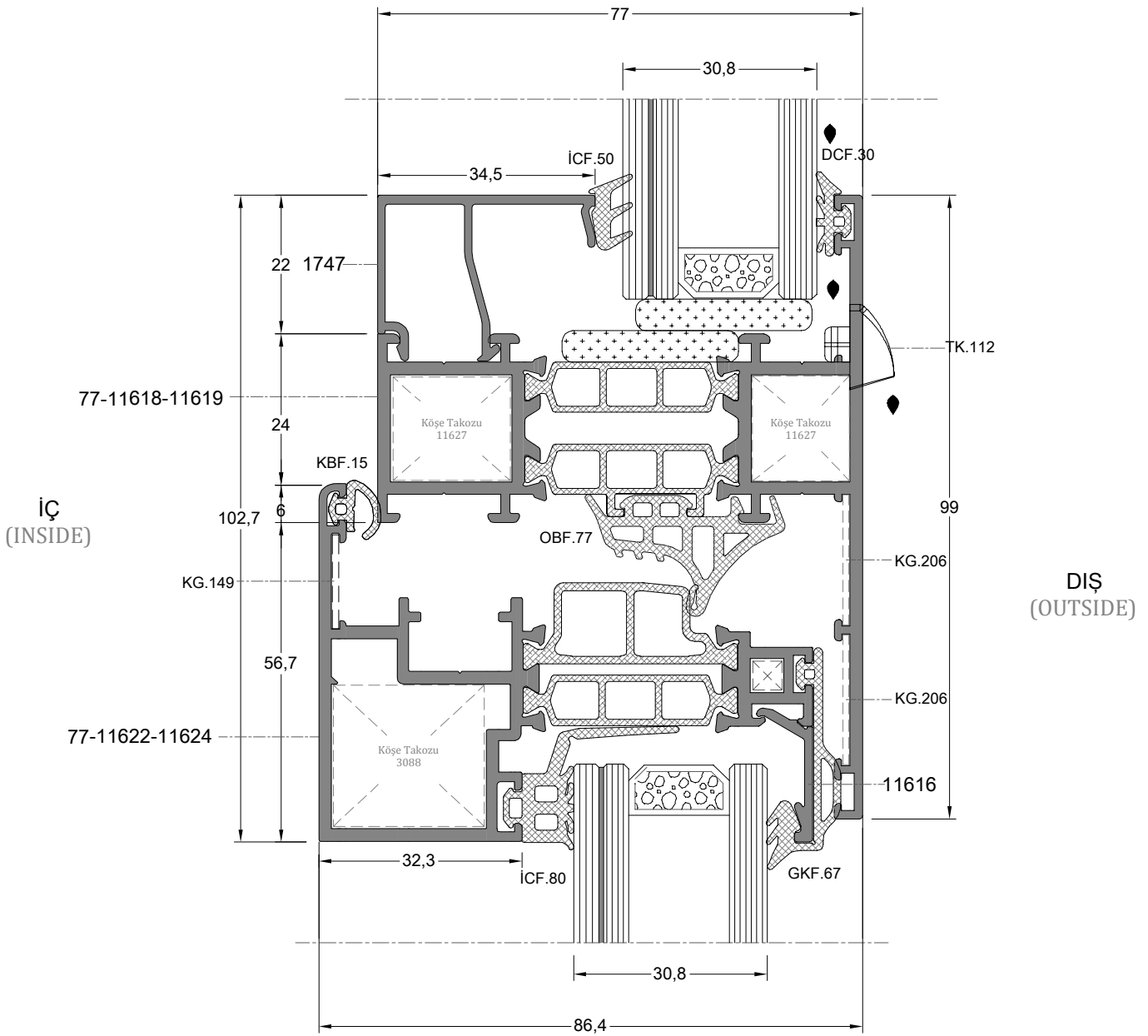
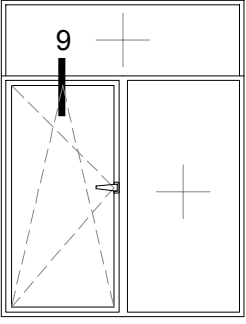

D-9

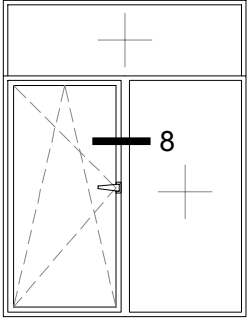

B N L ÇE AÇILIR ORTA KAYITLI DETAY
OVERLAPPING INWARD OPENING DETAIL WITH MULLION

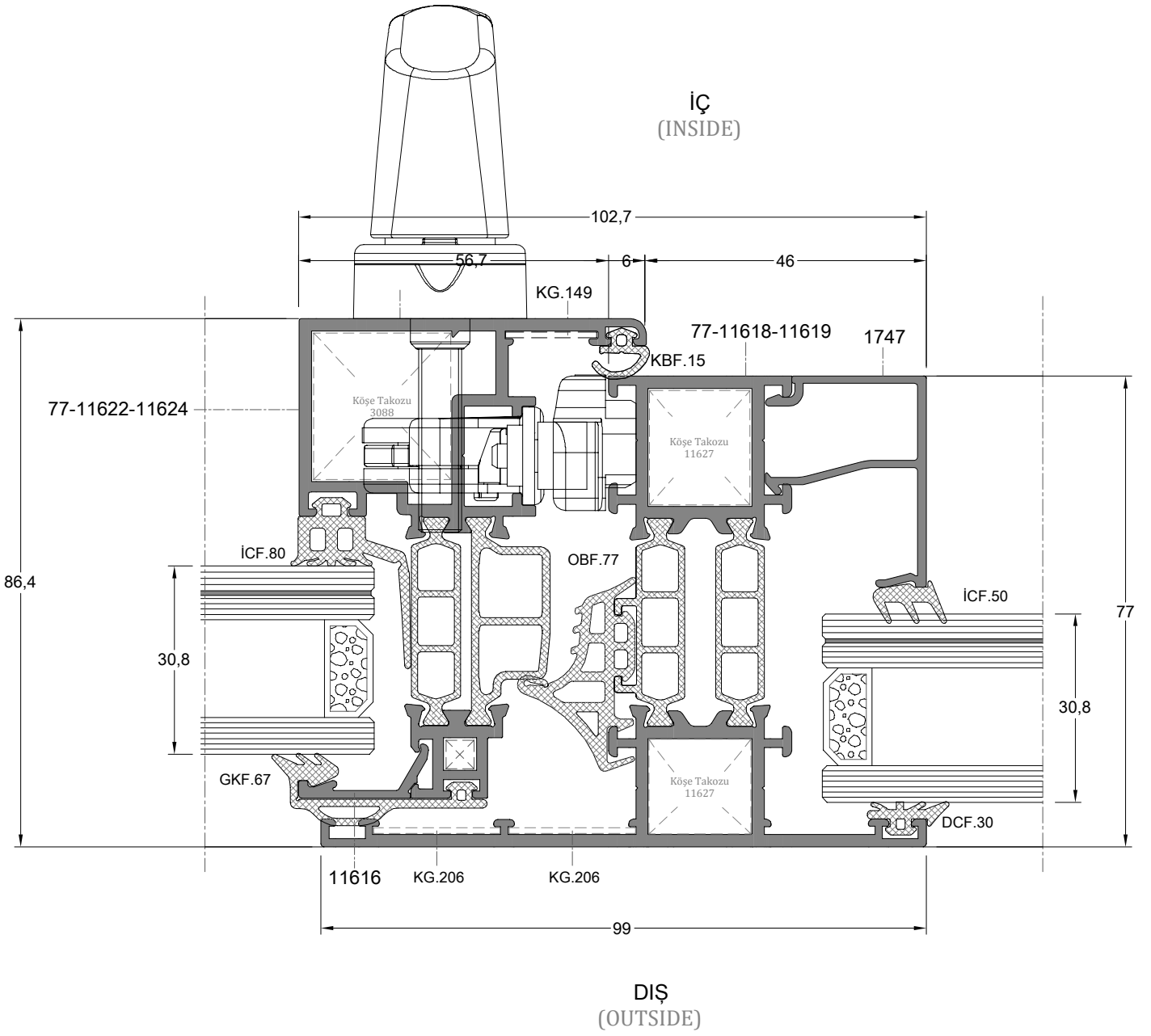

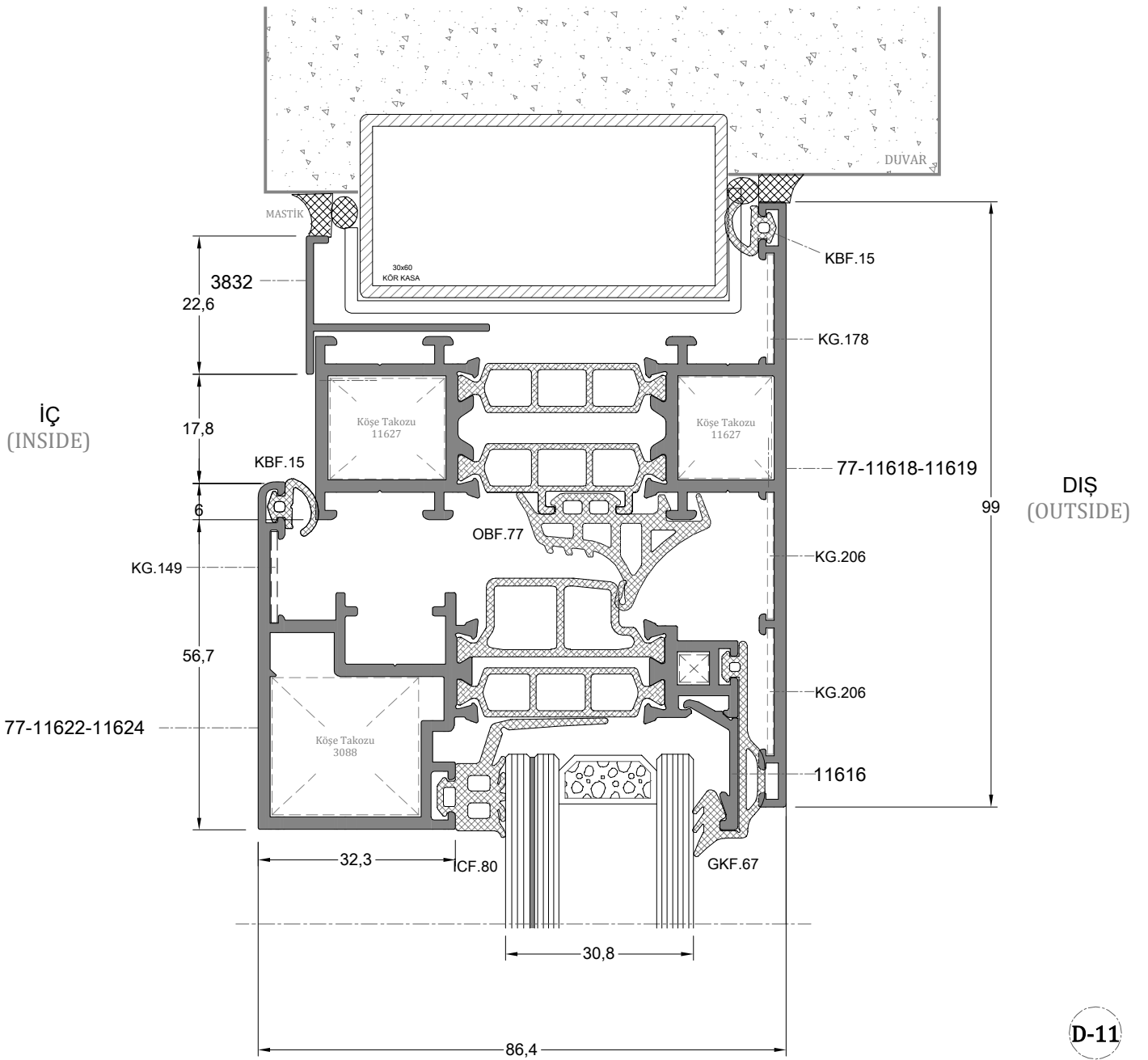
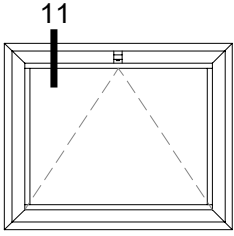

D-8

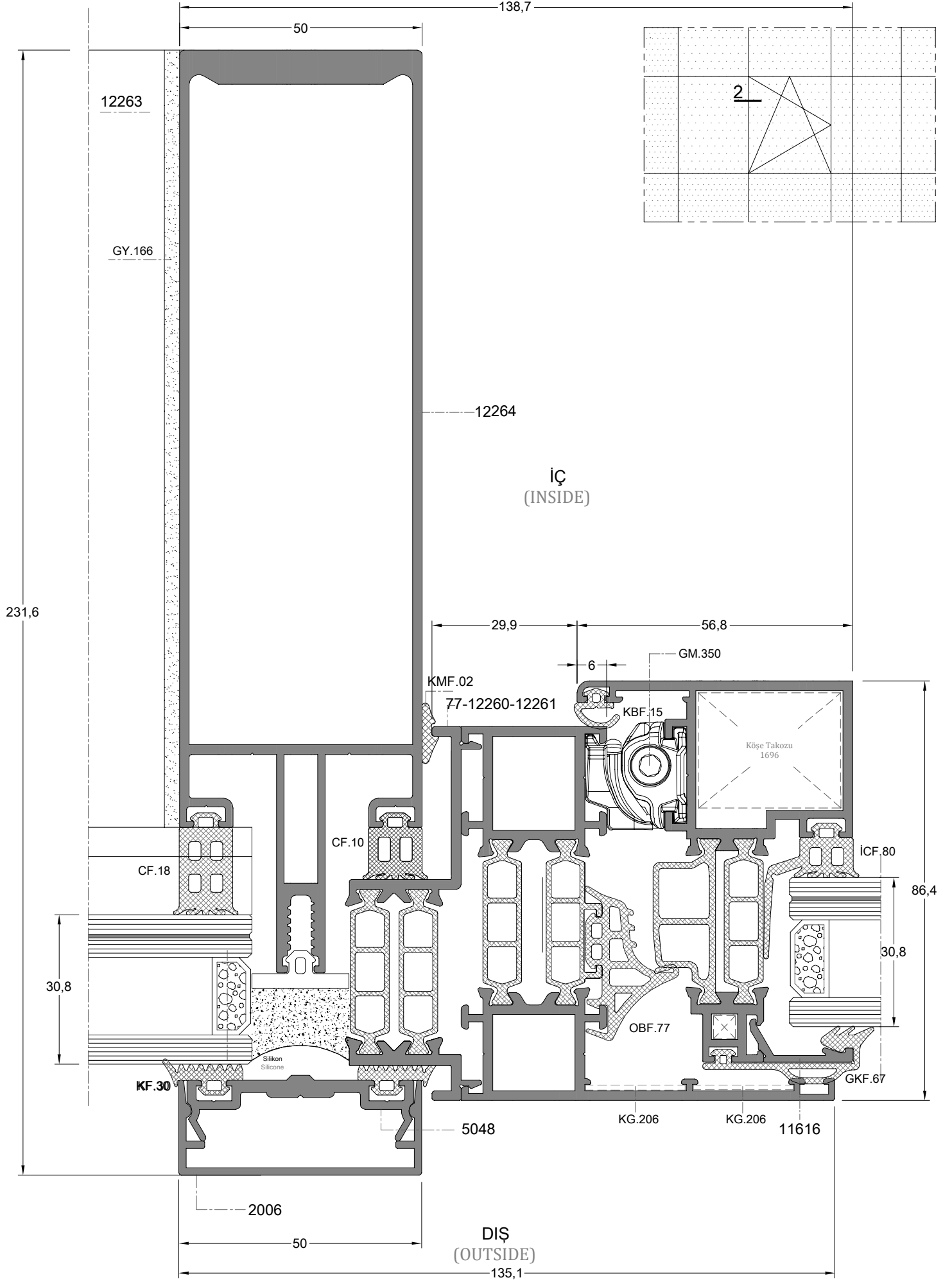

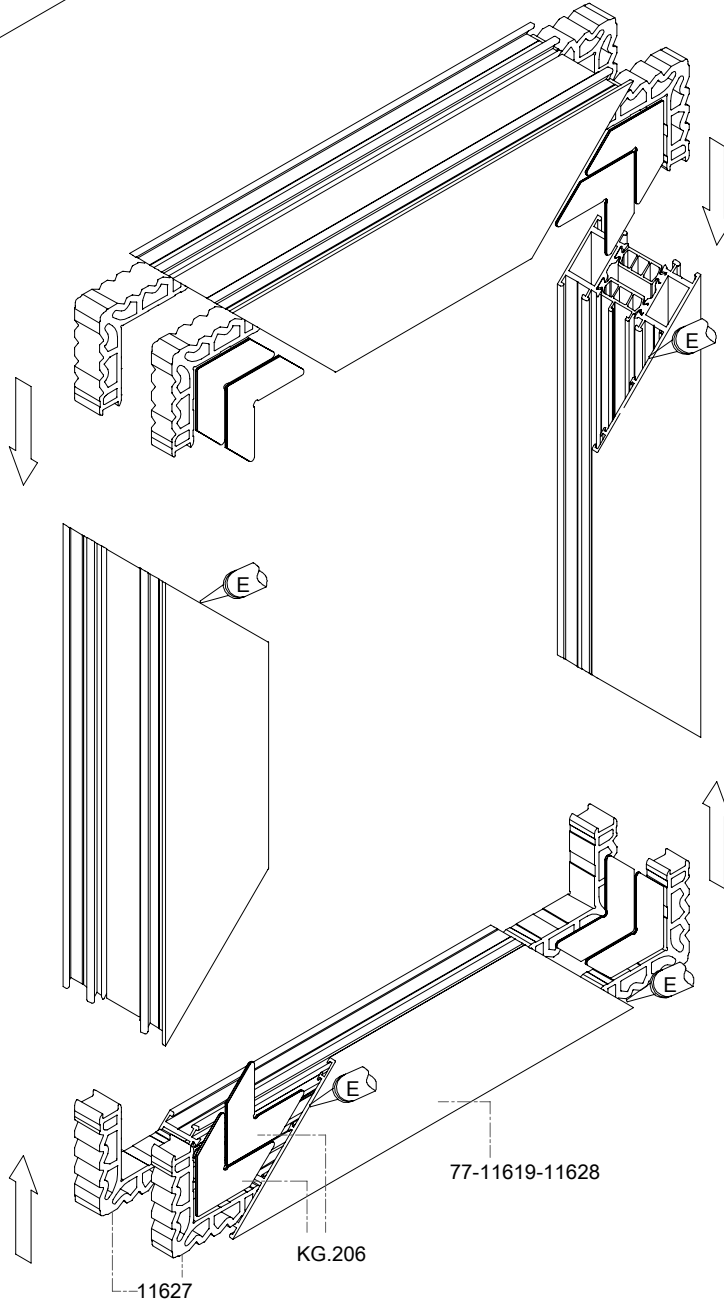
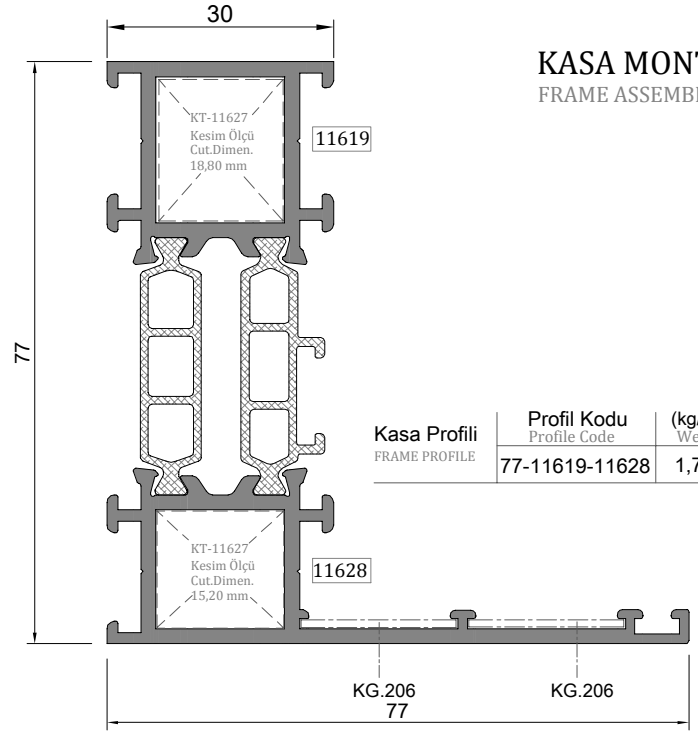
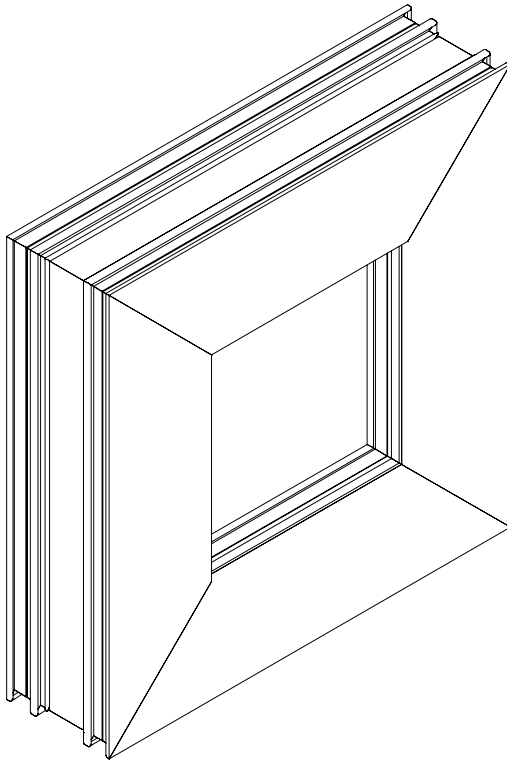

KASA MONTAJI
FRAME ASSEMBLY



 E : Epoksi / Epoxy

KANAT MONTAJI
SASH ASSEMBLY

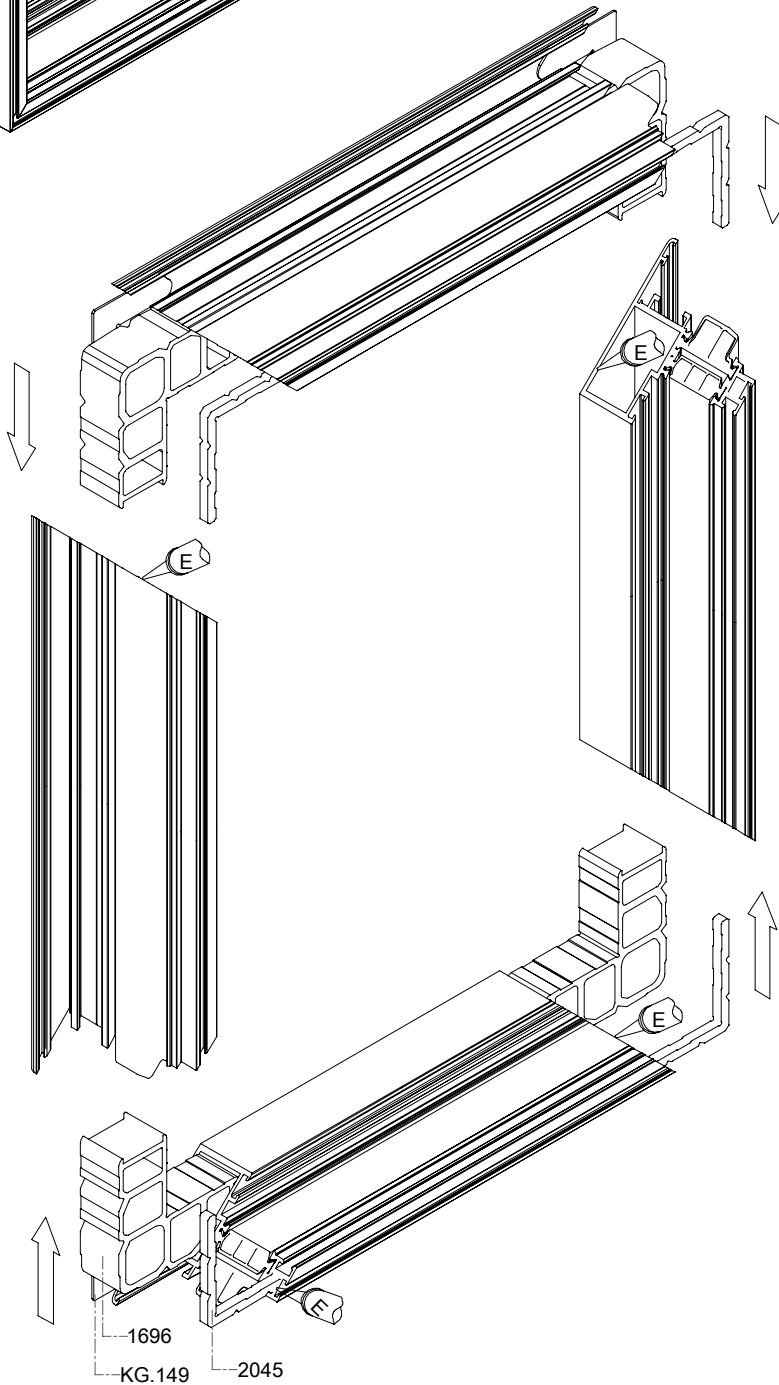
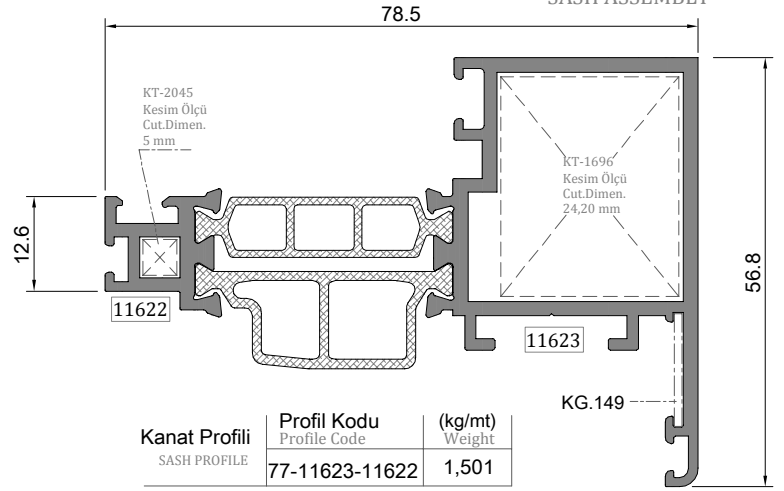
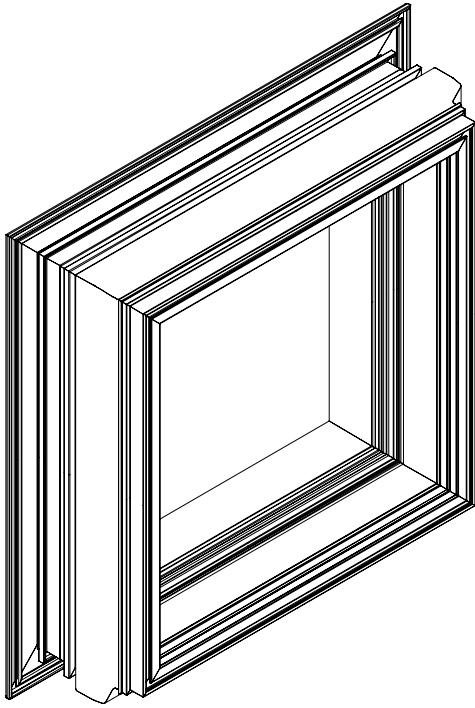

 E : Epoksi / Epoxy

CAM ÇITA MONTAJI
GLAZING BEAD ASSEMBLY

ADIM.1
STEP.1

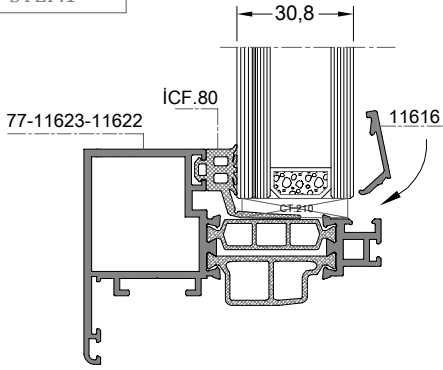

ADIM.4
STEP.1

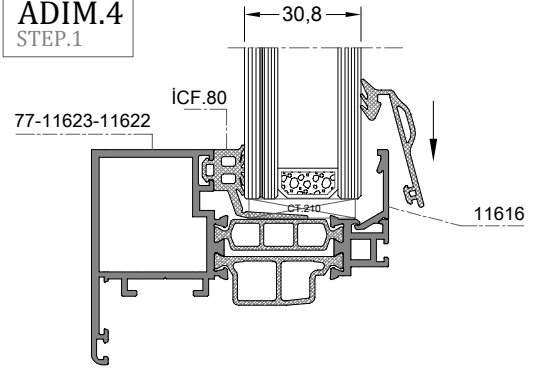

ADIM.2
STEP.1

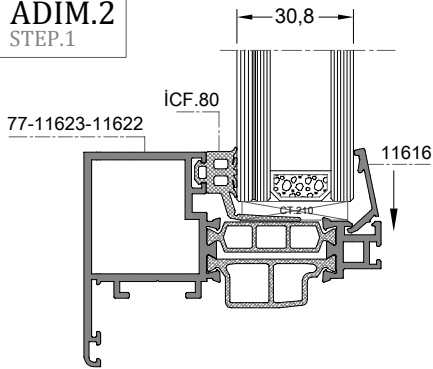

ADIM.5
STEP.1

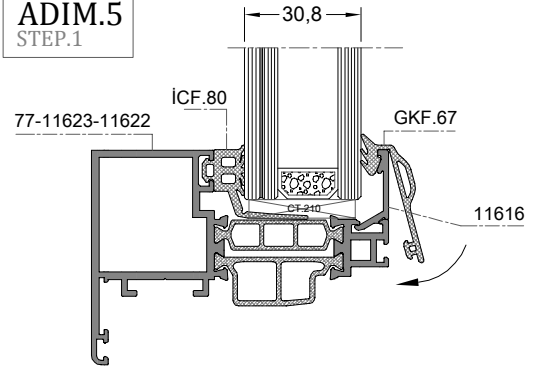

ADIM.3
STEP.1

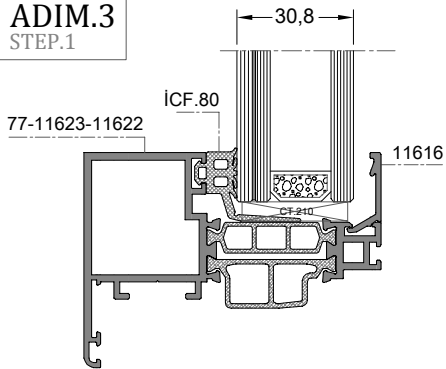

ADIM.6
STEP.1

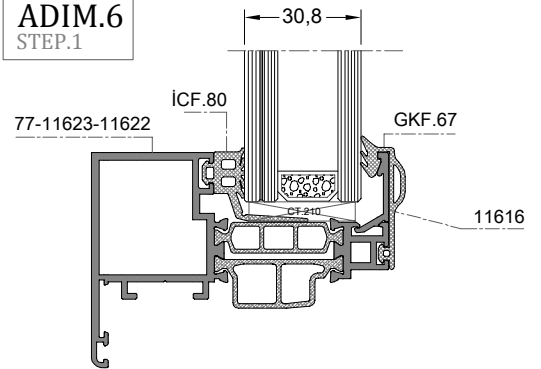

*Cam Montajında çift kanatta adaptör profilinin sökölüp kilit takımlarıyla tekrar takılması gerekmektedir.

SU TAHLİYE DETAYI
WATER DRAIN DETAYI

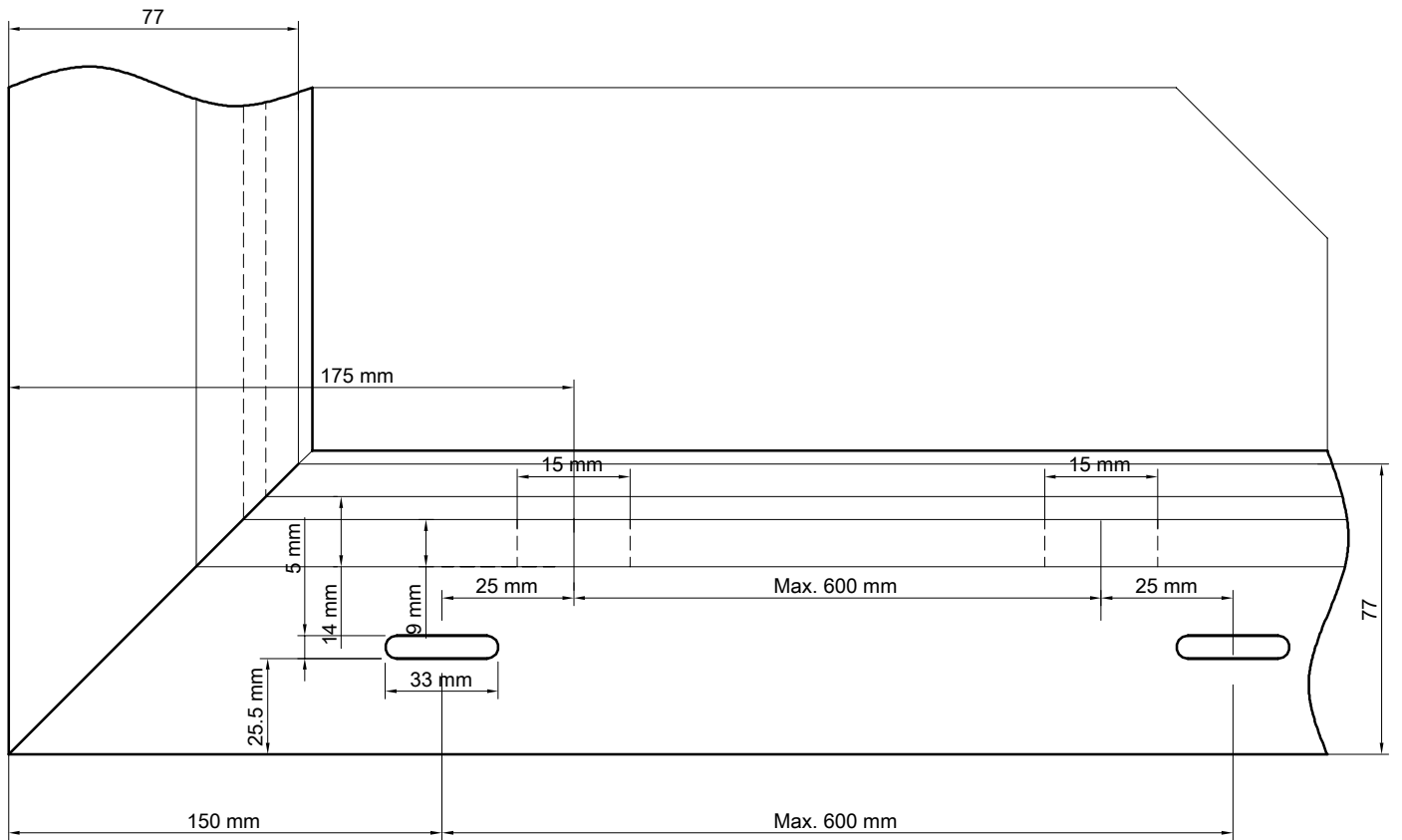
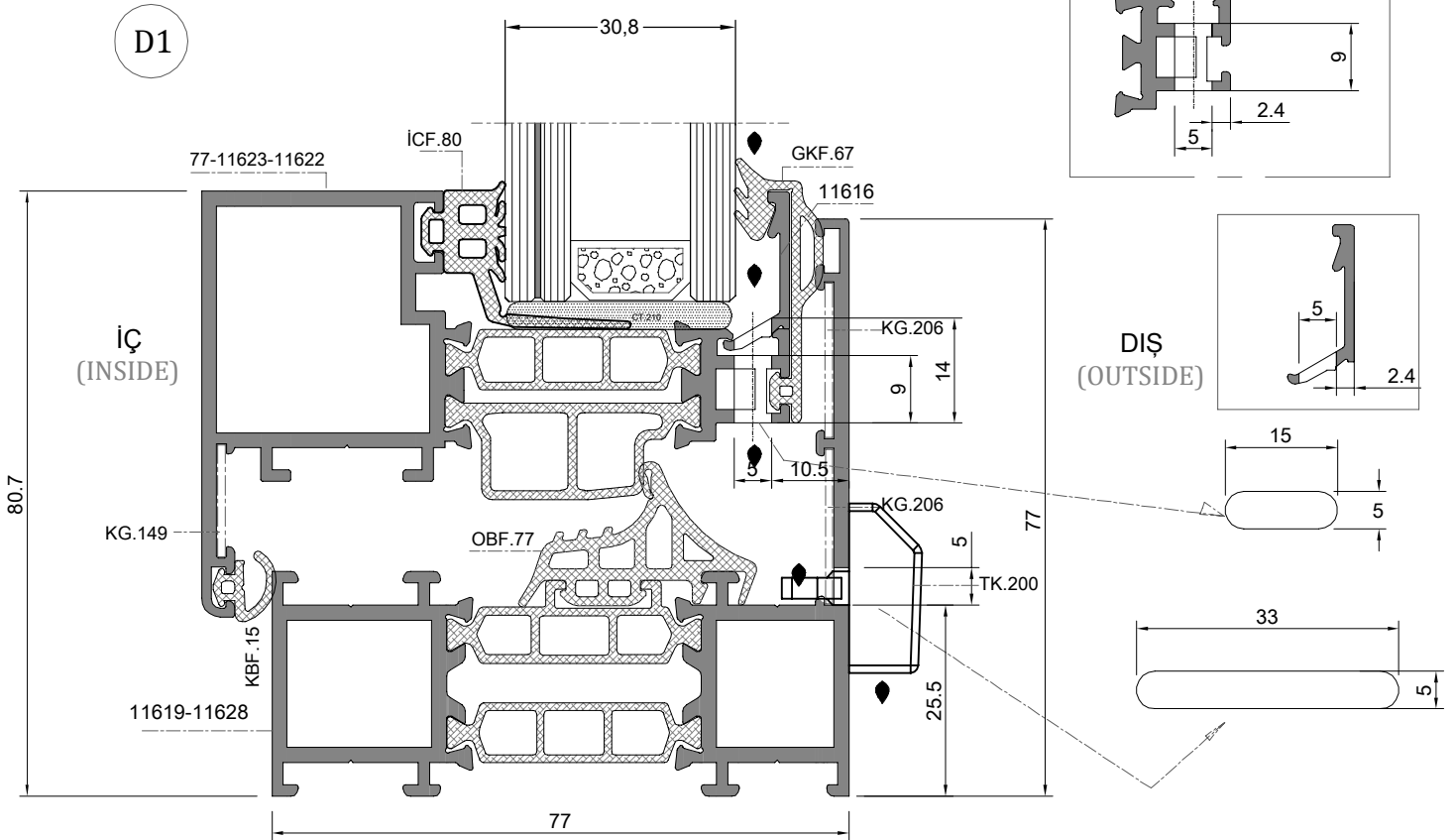

SU TAHLİYE DETAYI
WATER DRAIN DETAYI

D2

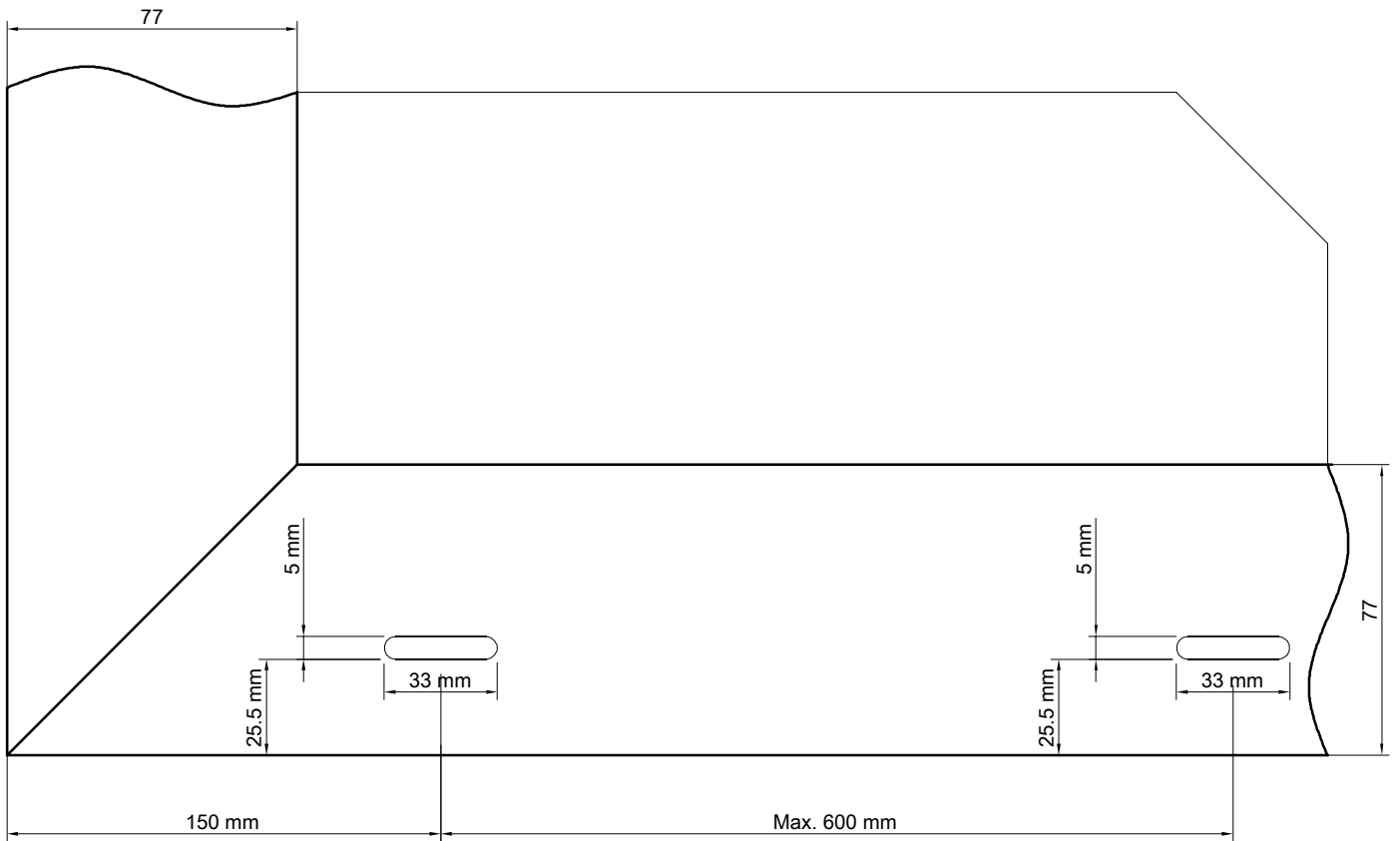
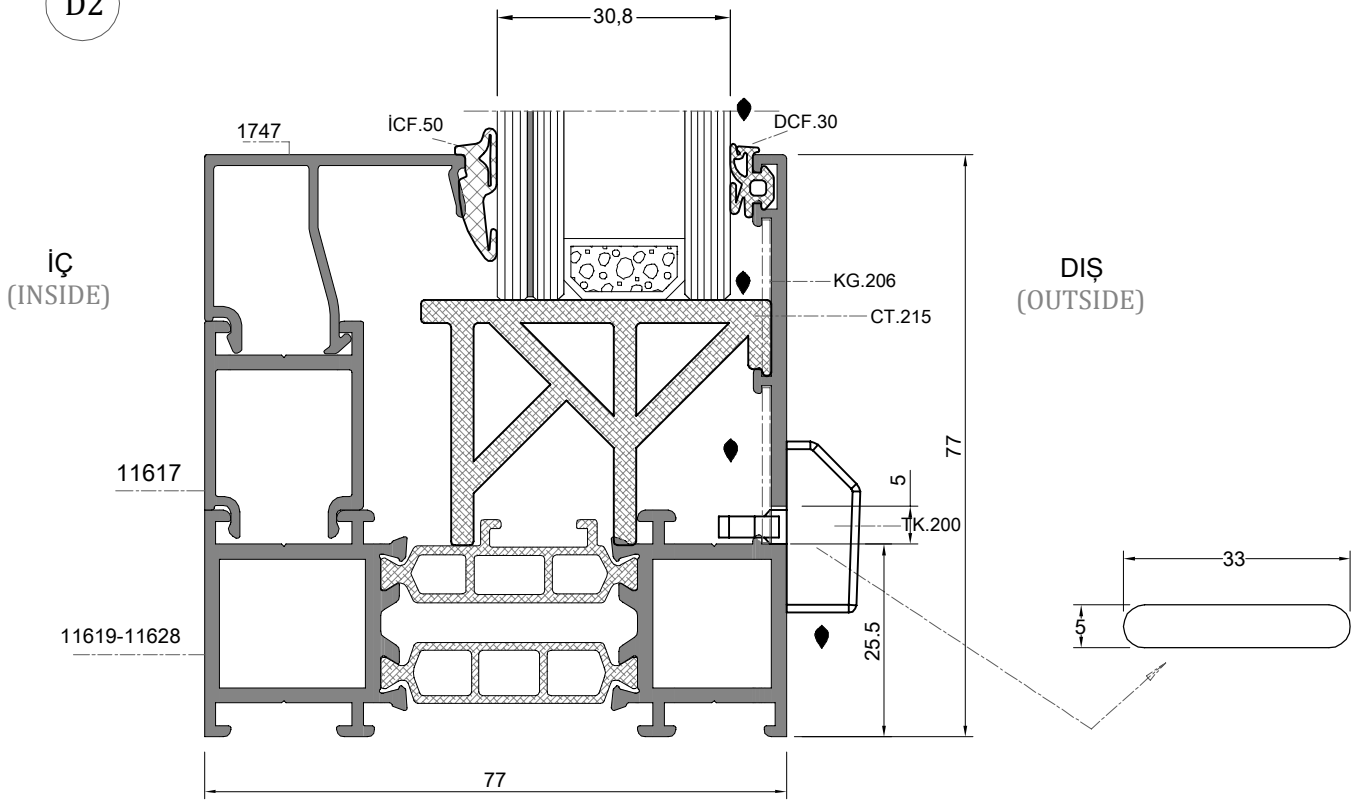

TAHLİYE KAPAĞI MONTAJ ŞEMASI

WATER DRAIN COVER ASSEMBLY INSTRUCTIONS

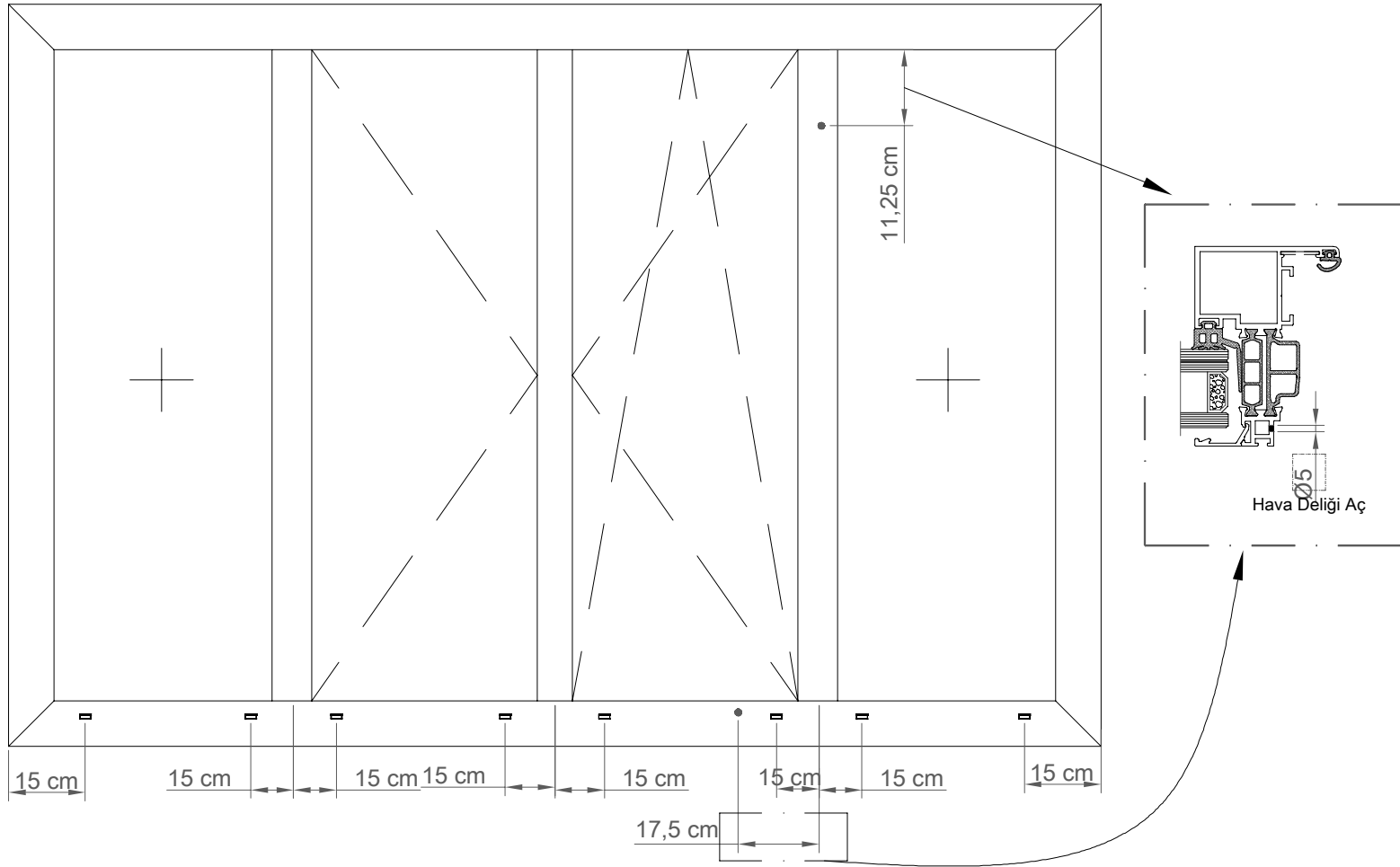

ORTA KAYIT BAĞLANTI DETAYI
MULLION CONNECTION DETAIL

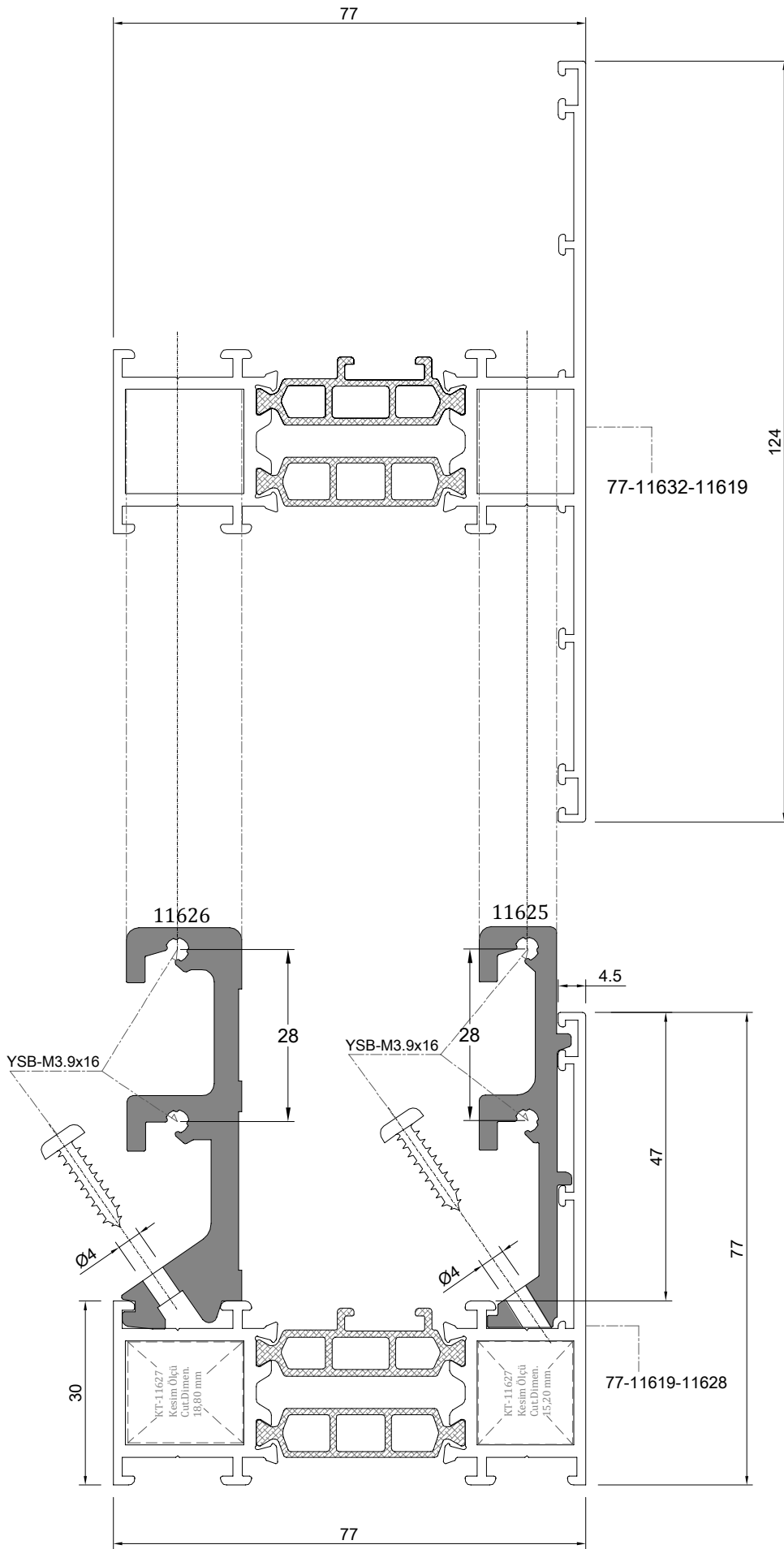

ORTA KAYIT BAĞLANTI DETAYI
MULLION CONNECTION DETAIL

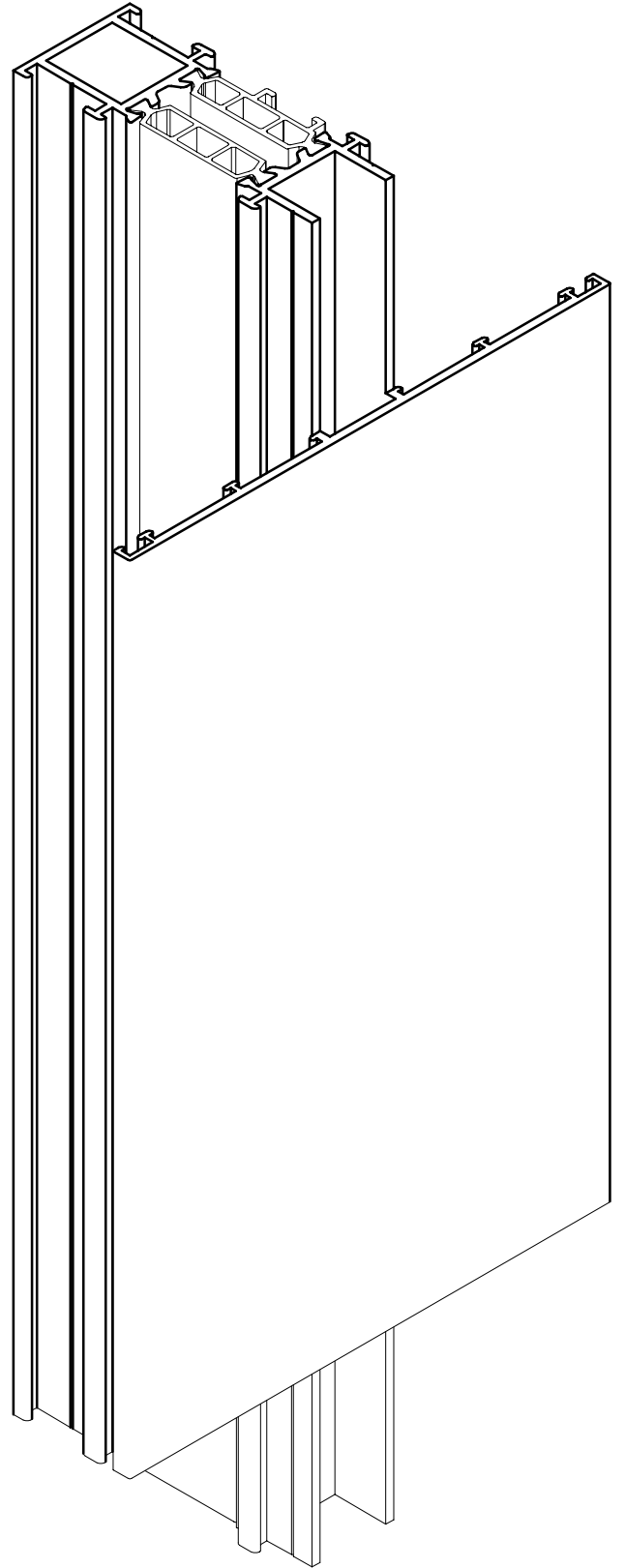
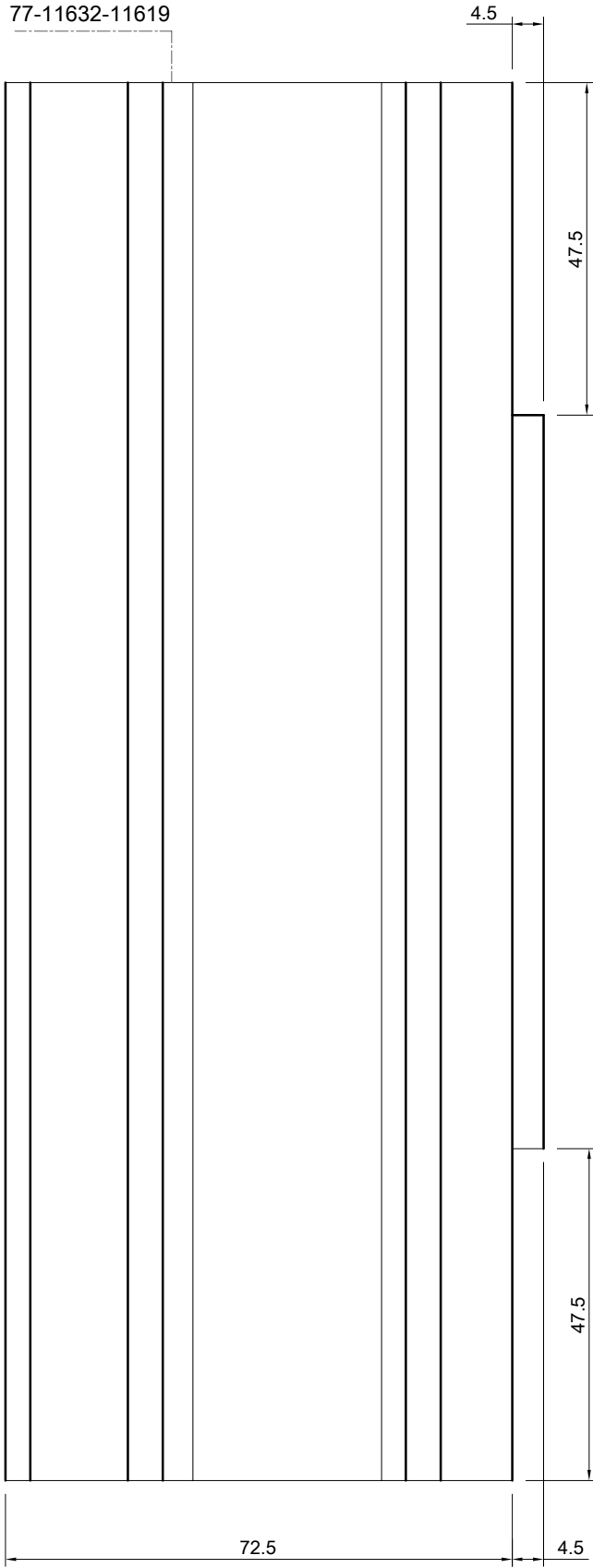

ORTA KAYIT BAĞLANTI DETAYI
MULLION CONNECTION DETAIL

MONTAJ ÖNCESİ İZOLASYON
PRE-FABRICATION INSULATION

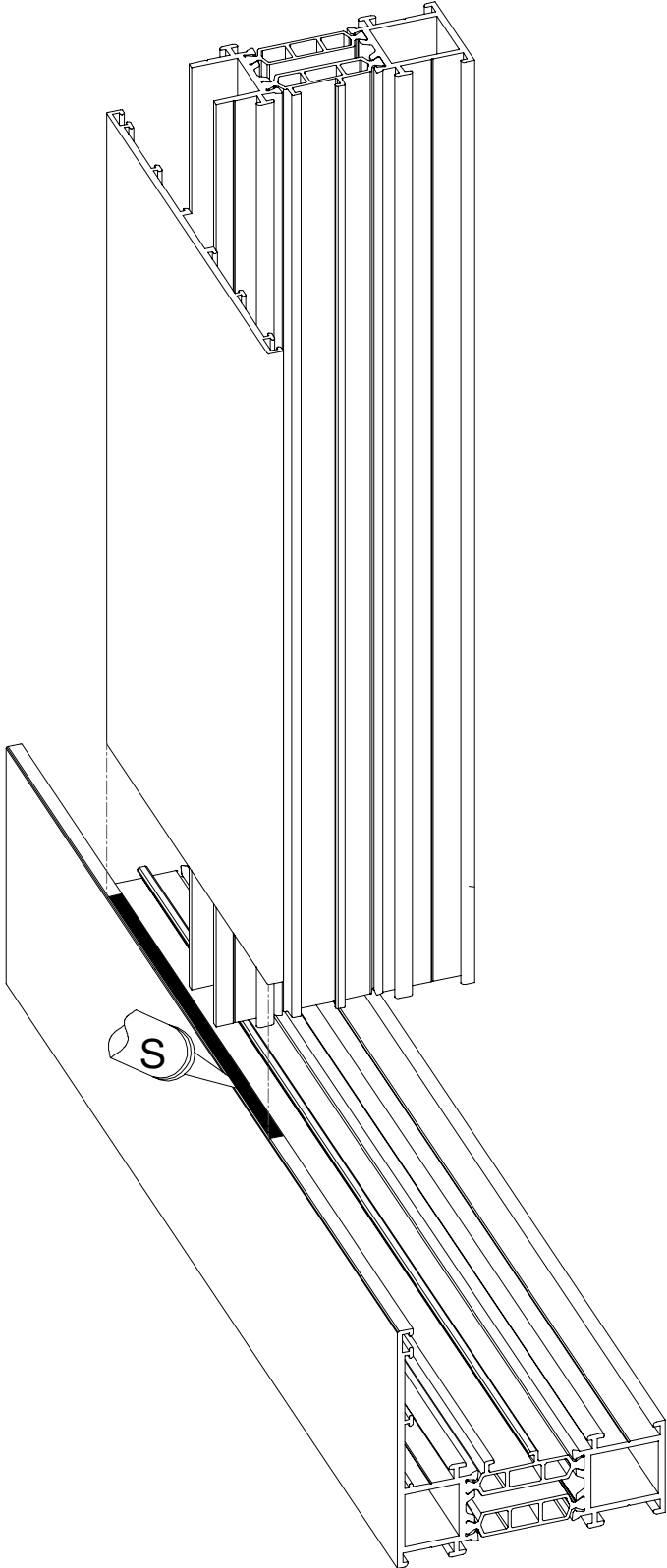

MONTAJ SONRASI İZOLASYON
POST-FABRICATION INSULATION

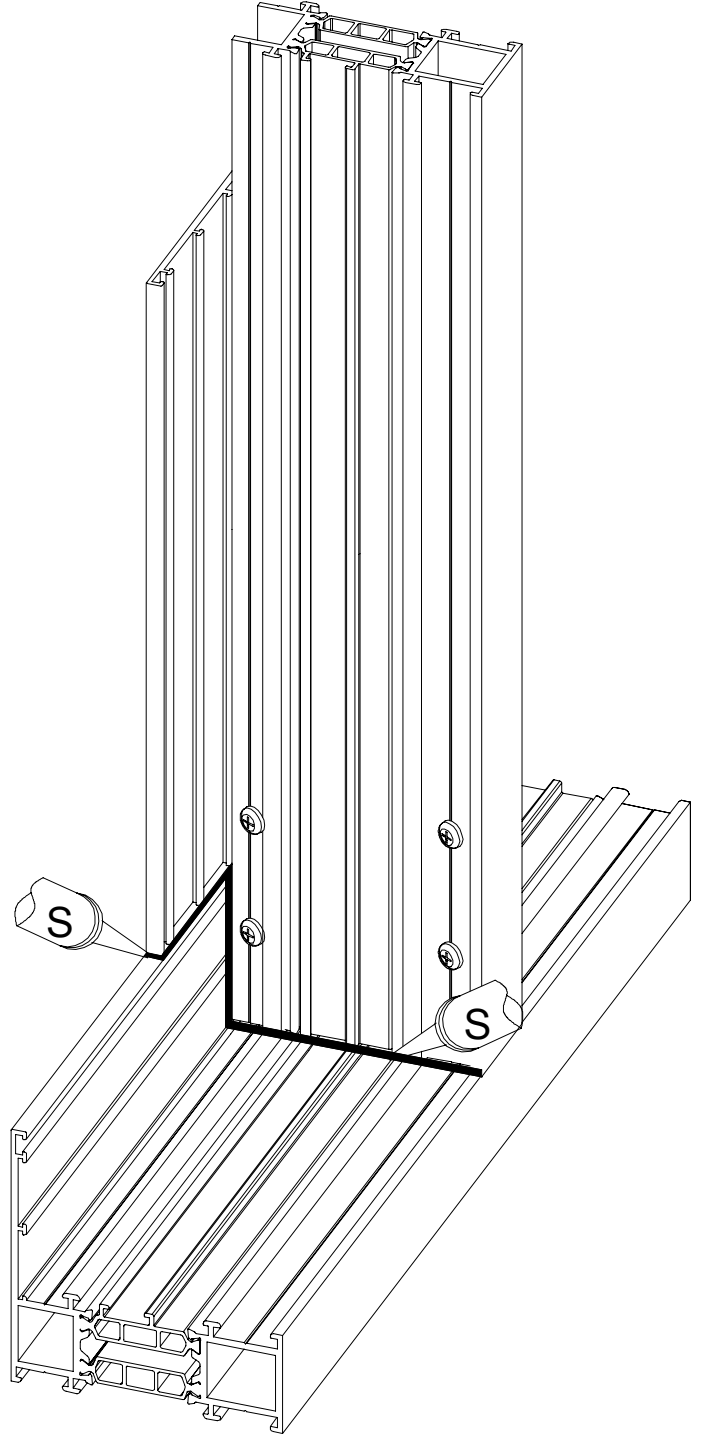

 S : Silikon/ Silicone

CAM MONTAJ TALİMATI
GLAZING FABRICATION INSTRUCTION

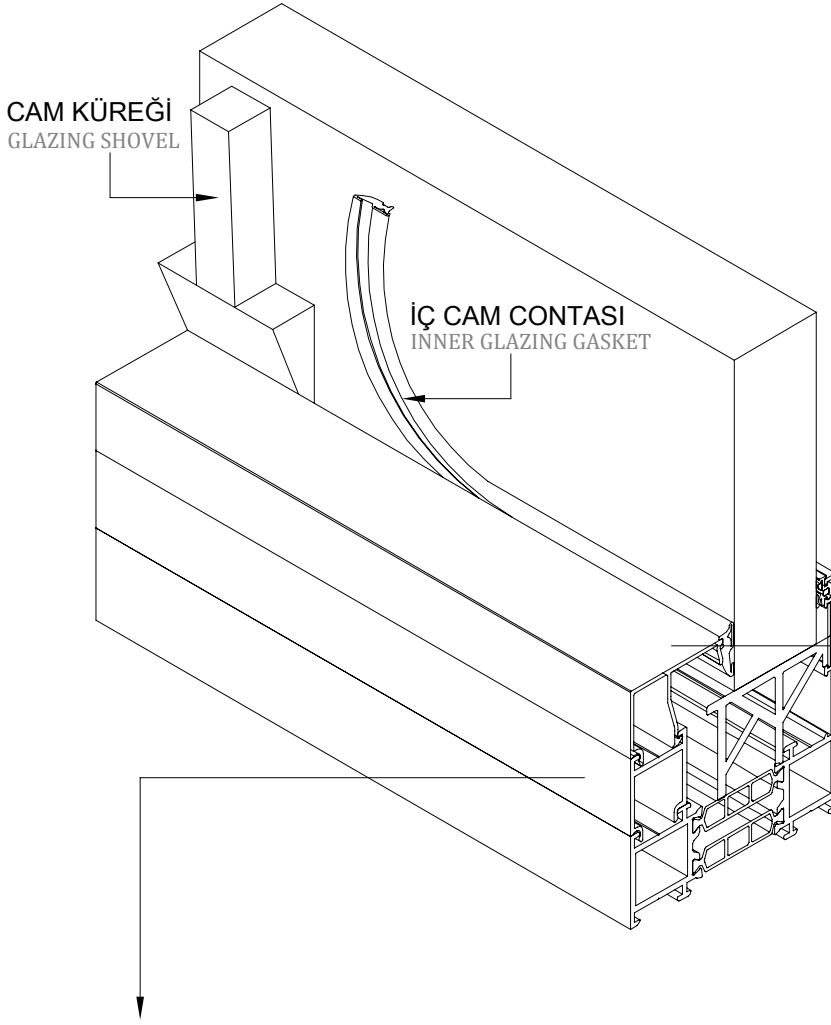

11617 UZATMA ÇİTASI MONTAJ
SIRALAMASI
11617 ORDER OF GLAZING ELEVATION BEAD ASSEMBLY

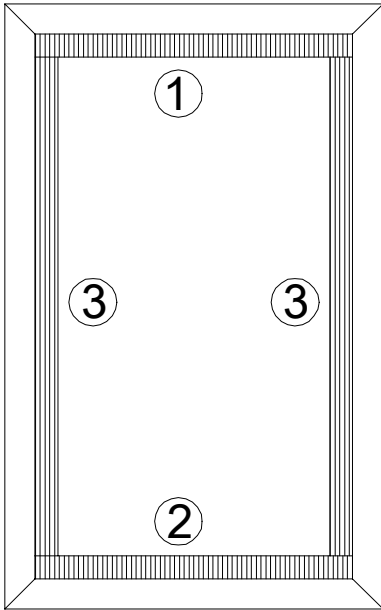

1747 CAM ÇİTASI MONTAJ
SIRALAMASI
1747 ORDER OF GLAZING BEAD ASSEMBLY

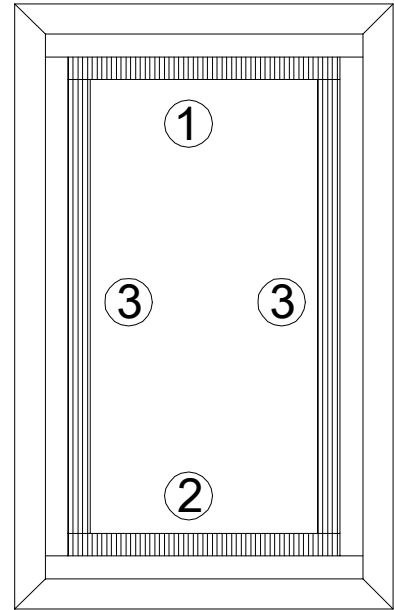

AKSESUAR VE DONANIM MONTAJINDAN ÖNCE CAM TAKOZLAMA İŞLEMİ YAPILMALIDIR.

BEFORE ACCESSORY AND HARDWARE ASSEMBLY, POSITIONING OF THE GLASS SHOULD BE DONE.

CAM MONTAJ TALİMATI
GLAZING FABRICATION INSTRUCTION

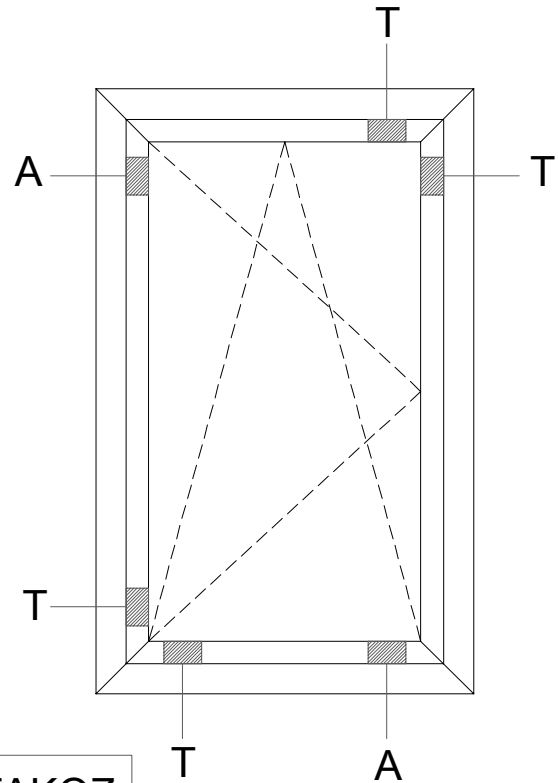
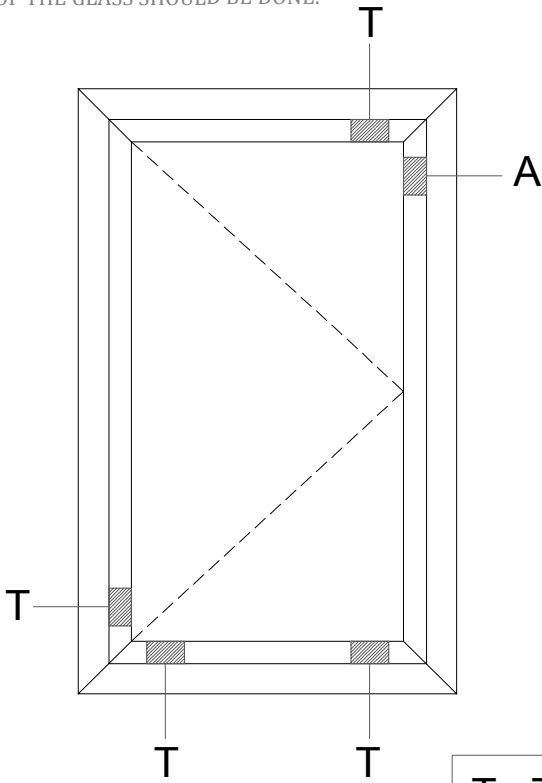

T : TAŞIYICI TAKOZ
T : CARRIER WEDGE
A : AYAR TAKOZU
A : ADJUSTING WEDGE

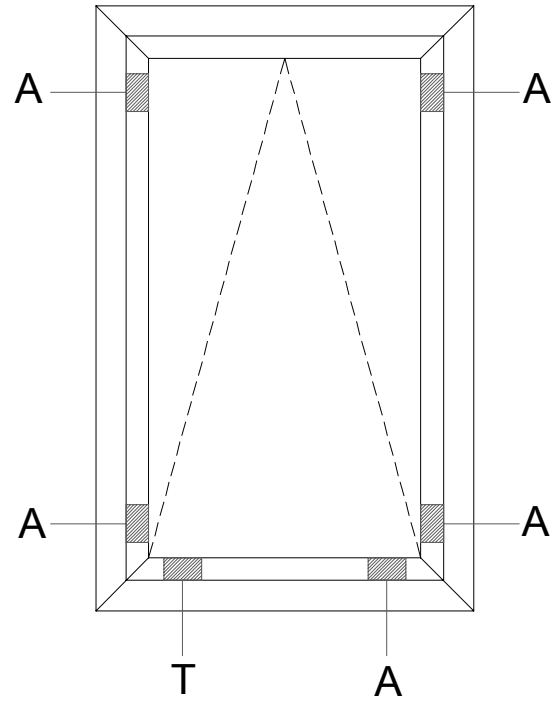
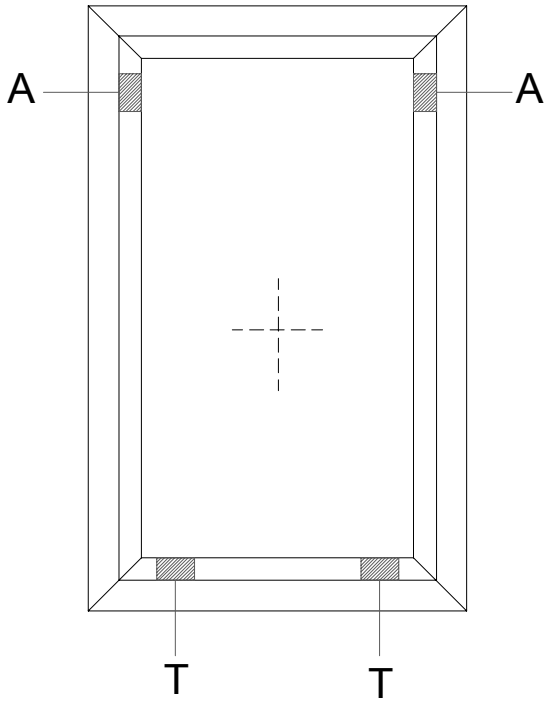

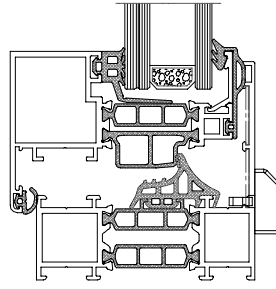
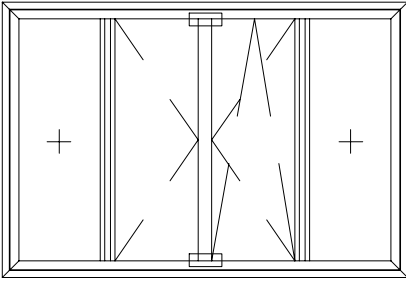

**ÇİFT KANATLI DOĞRAMADA
ORTA CONTA KERTME ÖLÇÜSÜ**
MIDDLE GASKET NOTCHING DETAIL FOR
DOUBLE SASHED WINDOW

YATAY DETAY
HORIZONTAL DETAIL

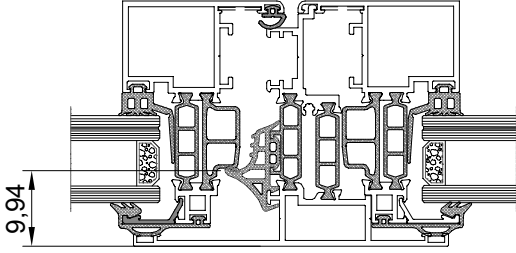

DÜŞEY DETAY
VERTICAL DETAIL

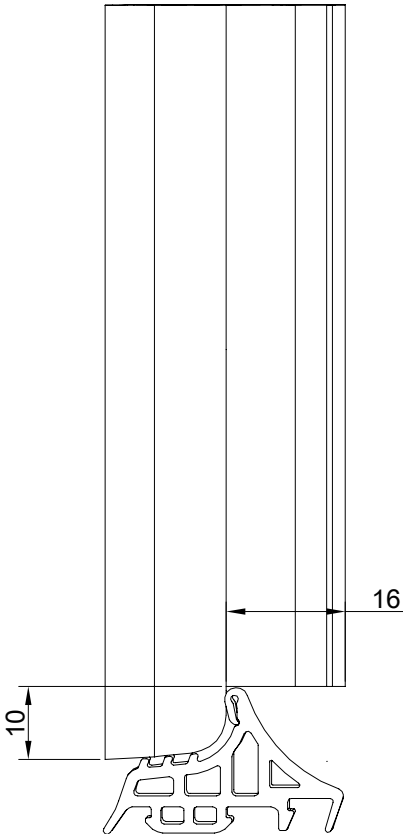
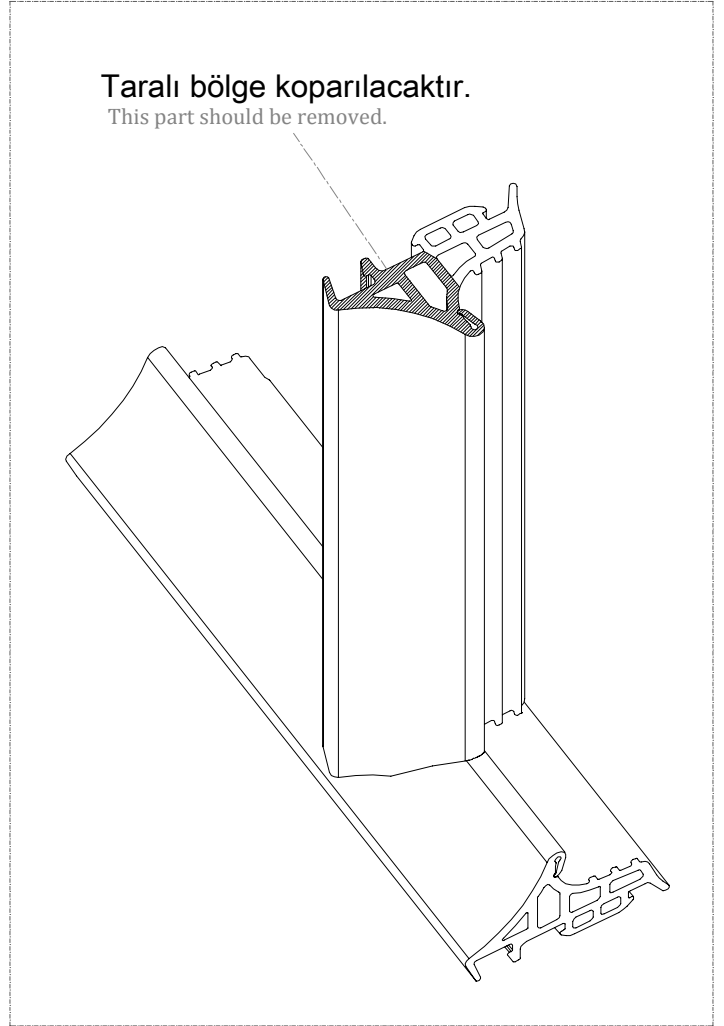

Falçata
Curved
Knife

